

*SADDLES ARE SEAL WELDED TO TANK

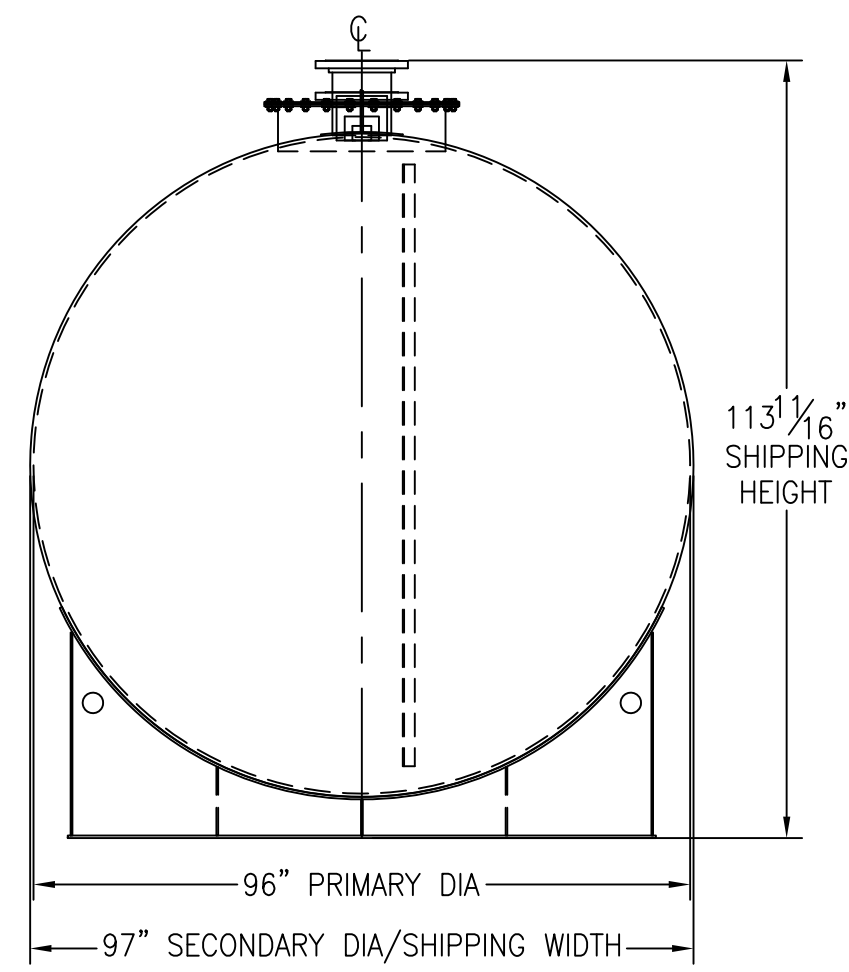
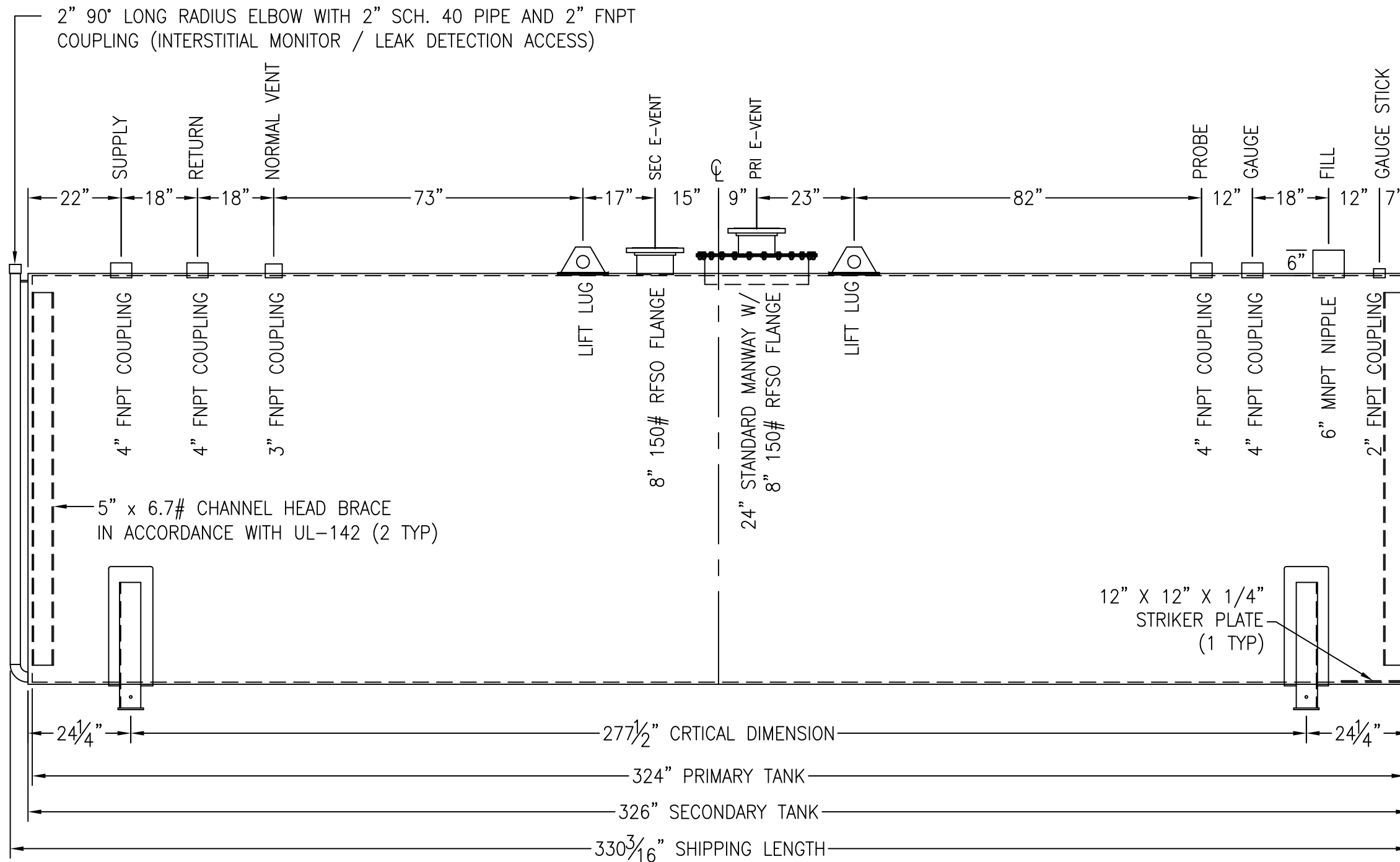

CUSTOMER APPROVAL SIGNATURE/DATE:

10,000 GALLON HORIZONTAL D/W ABOVE GROUND TANK

SURFACE PREPARATION/COATING INFORMATION:
 INTERIOR SURFACES: SSPC-SP-3 POWER TOOL CLEAN WELDS ONLY
 REMOVE ALL LOOSE DEBRIS
 EXTERIOR SURFACES: SSPC-SP-6 COMMERCIAL BLAST CLEAN
 5-7 MILS ALIPHATIC URETHANE (WHITE)

MATERIAL /CONSTRUCTION/ LABELING INFORMATION:
 MATERIAL: CARBON STEEL ASTM A 36 OR A 569
 MATERIAL THICKNESS: PRIMARY TANK SHELL AND HEADS: 1/4"
 SECONDARY TANK SHELL: 10 GA HEADS: 1/4"

LABELING/MARKING: UNDERWRITERS LABORATORIES UL-142/STI F-921

CUSTOMER:
 PROJECT:
 AGENT:



P.O. BOX 1279 GOLDSBORO, NC 27533
 PHONE: (919)751-1791 FAX: (919)751-8186

DRAWING NUMBER: **GIDH10K96** REVISED 7/14

QUANTITY: ONE (1) REQUIRED
 WEIGHT: 14,750 lbs ± 10%

*SADDLES ARE SEAL WELDED TO TANK

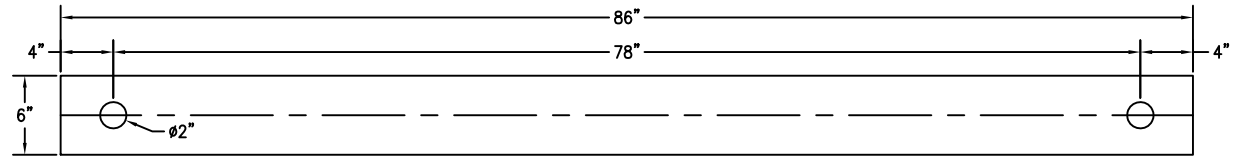

BASE PLATE ANCHOR HOLE DETAIL

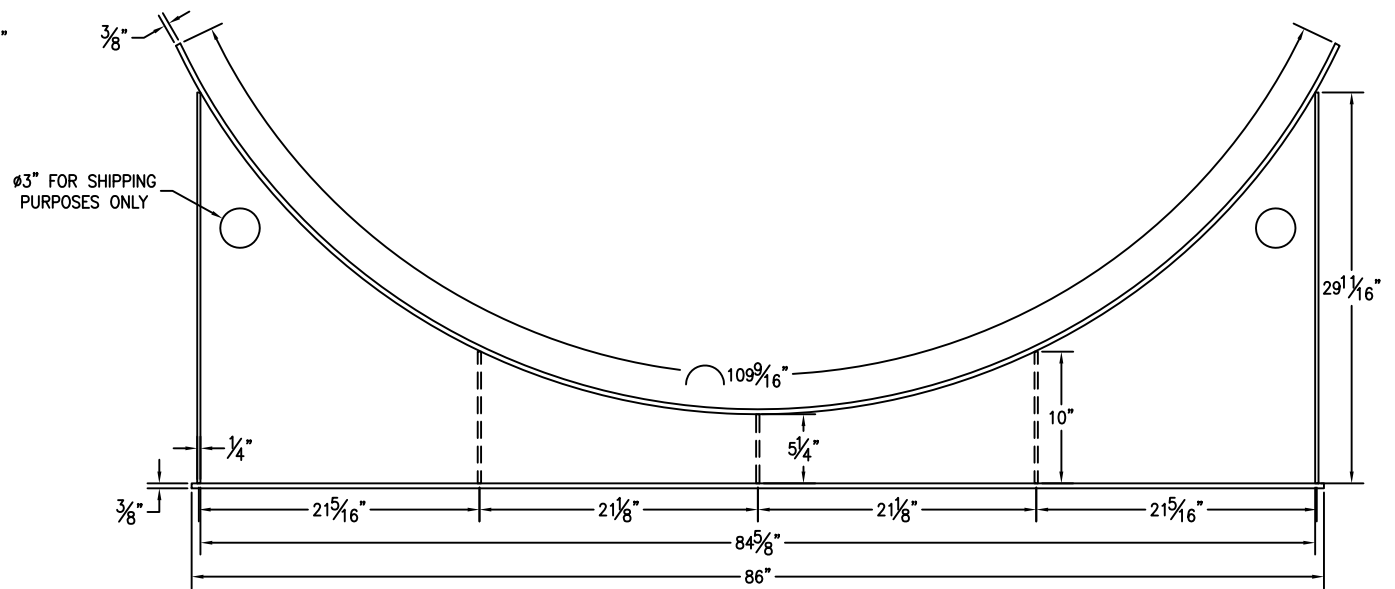
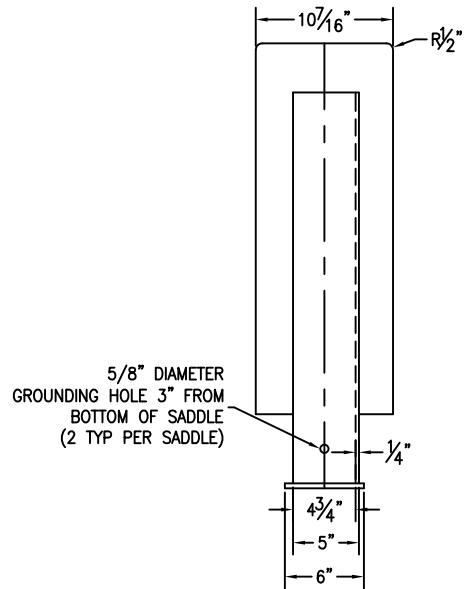

CUSTOMER APPROVAL SIGNATURE/DATE:

10,000 GAL 6" TALL SADDLE FOR 97" DIAMETER TANK

SURFACE PREPARATION/COATING INFORMATION:

EXTERIOR SURFACES: SSPC-SP-6 COMMERCIAL BLAST CLEAN
5-7 MILS ALIPHATIC URETHANE (WHITE)

MATERIAL /CONSTRUCTION/ LABELING INFORMATION:

MATERIAL: CARBON STEEL ASTM A 36 OR A 569

CUSTOMER:
PROJECT:
AGENT:



P.O. BOX 1279 GOLDSBORO, NC 27533
PHONE: (919)751-1791 FAX: (919)751-8186

DRAWING NUMBER: GI-S609710DW REVISED 7/14

QUANTITY: TWO (2) REQUIRED
WEIGHT: 318 lb ± 10%