

*SADDLES ARE SEAL WELDED TO TANK

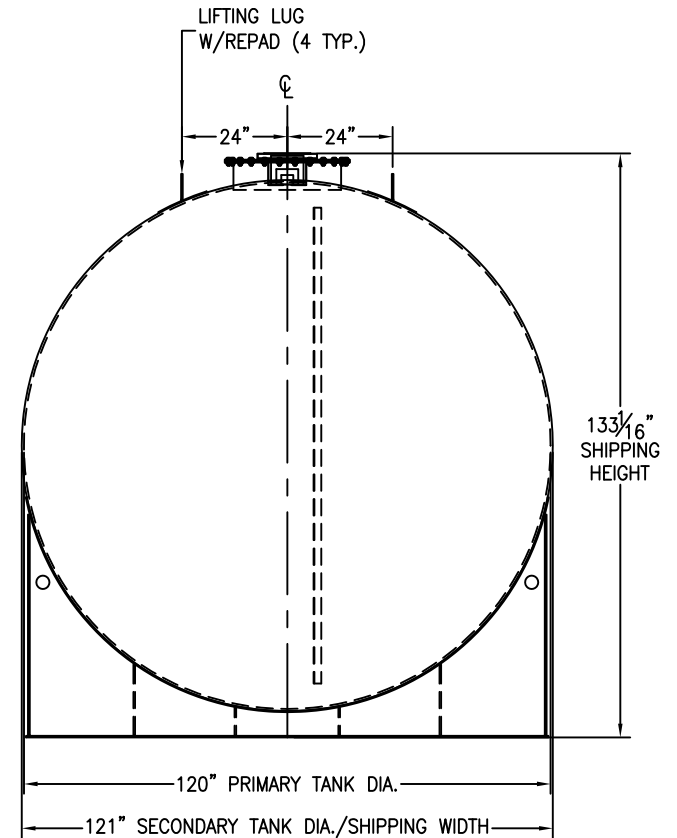

2" 90° LONG RADIUS ELBOW WITH 2" SCH. 40 PIPE AND 2" FNPT COUPLING
(INTERSTITIAL MONITOR / LEAK DETECTION ACCESS)

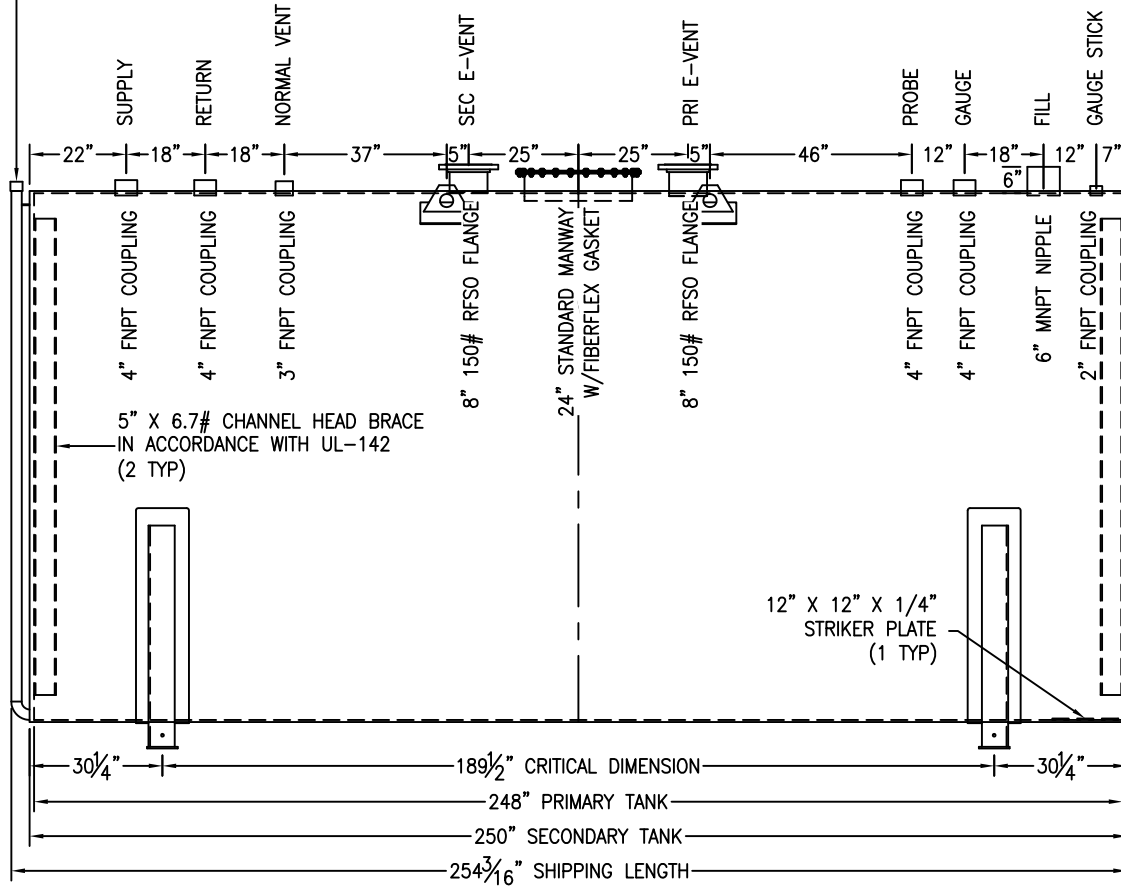

CUSTOMER APPROVAL SIGNATURE/DATE:

12,000 GALLON HORIZONTAL D/W ABOVE GROUND TANK

SURFACE PREPARATION/COATING INFORMATION:
 INTERIOR SURFACES: SSPC-SP-3 POWER TOOL CLEAN WELDS ONLY
 REMOVE ALL LOOSE DEBRIS
 EXTERIOR SURFACES: SSPC-SP-6 COMMERCIAL BLAST CLEAN
 5-7 MILS ALIPHATIC URETHANE (WHITE)

MATERIAL /CONSTRUCTION/ LABELING INFORMATION:
 MATERIAL: CARBON STEEL ASTM A 36 OR A 569
 MATERIAL THICKNESS: PRIMARY TANK SHELL AND HEADS: 1/4"
 SECONDARY TANK SHELL: 7 GA HEADS: 1/4"

LABELING/MARKING: UNDERWRITERS LABORATORIES UL-142

CUSTOMER:
 PROJECT:
 AGENT:



P.O. BOX 1279 GOLDSBORO, NC 27533
 PHONE: (919)751-1791 FAX: (919)751-8186

DRAWING NUMBER: GIDH12K120 REVISED 7/14

QUANTITY: ONE (1) REQUIRED
 WEIGHT: 17,250 lbs ± 10%

*SADDLES ARE SEAL WELDED TO TANK

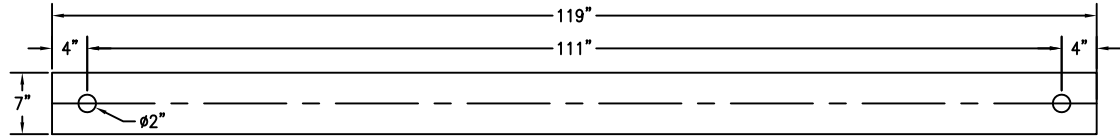

BASE PLATE ANCHOR HOLE DETAIL

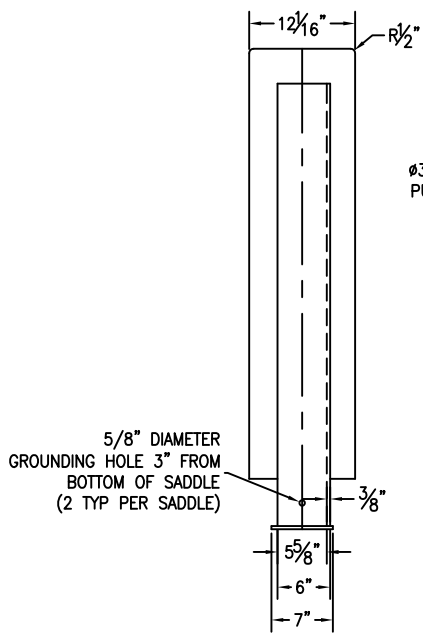

5/8" DIAMETER GROUNDING HOLE 3" FROM BOTTOM OF SADDLE (2 TYP PER SADDLE)

Ø3" FOR SHIPPING PURPOSES ONLY

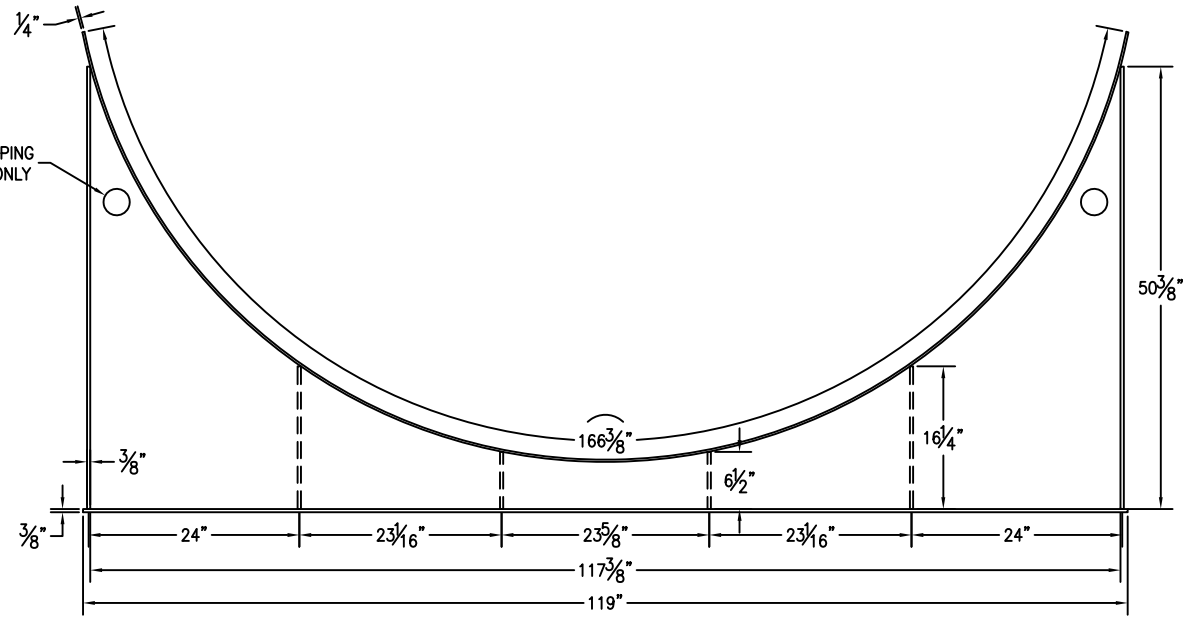

CUSTOMER APPROVAL SIGNATURE/DATE:

QUANTITY: TWO (2) REQUIRED
WEIGHT: 666 lb ± 10%

12,000 GAL 6" TALL SADDLE FOR 121" DIAMETER TANK

SURFACE PREPARATION/COATING INFORMATION:

EXTERIOR SURFACES: SSPC-SP-6 COMMERCIAL BLAST CLEAN
5-7 MILS ALIPHATIC URETHANE (WHITE)

MATERIAL /CONSTRUCTION/ LABELING INFORMATION:

MATERIAL: CARBON STEEL ASTM A 36 OR A 569

CUSTOMER:
PROJECT:
AGENT:

P.O. BOX 1279 GOLDSBORO, NC 27533
PHONE: (919)751-1791 FAX: (919)751-8186

DRAWING NUMBER: GI-S612112DW REVISED 7/14