

\*SADDLES ARE SEAL WELDED TO TANK

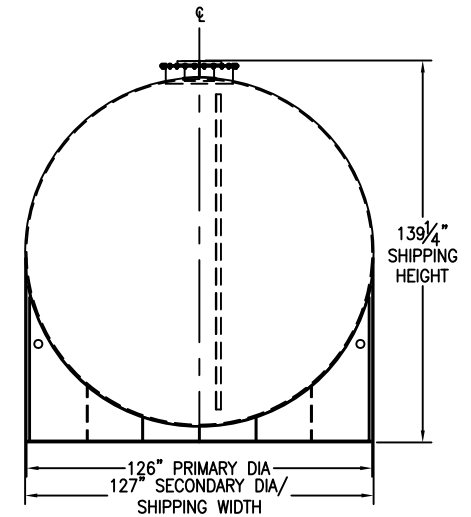
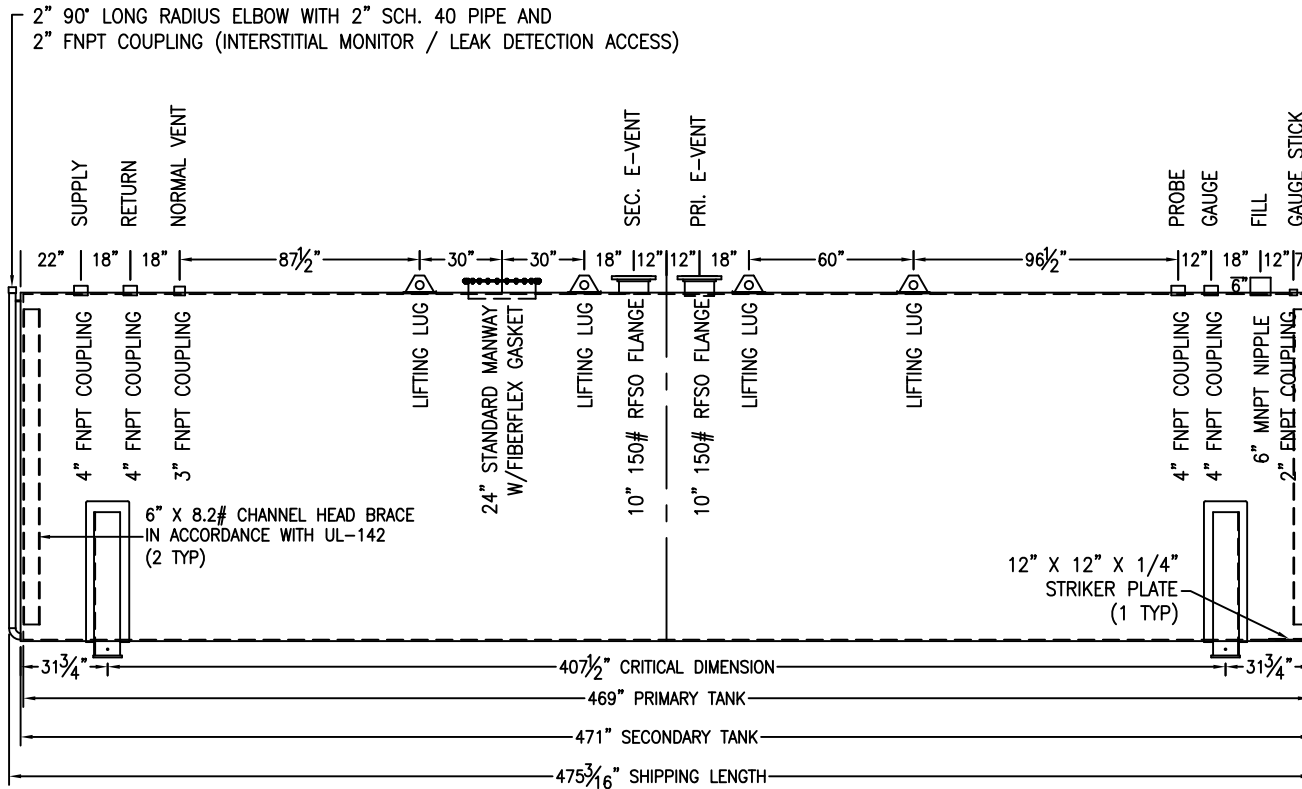

CUSTOMER APPROVAL SIGNATURE/DATE:

25,000 GALLON HORIZONTAL D/W ABOVE GROUND TANK

SURFACE PREPARATION/COATING INFORMATION:  
 INTERIOR SURFACES: SSPC-SP-3 POWER TOOL CLEAN WELDS ONLY  
 REMOVE ALL LOOSE DEBRIS  
 EXTERIOR SURFACES: SSPC-SP-6 COMMERCIAL BLAST CLEAN  
 5-7 MILS ALIPHATIC URETHANE (WHITE)

MATERIAL /CONSTRUCTION/ LABELING INFORMATION:  
 MATERIAL: CARBON STEEL ASTM A 36 OR A 569  
 MATERIAL THICKNESS: PRIMARY TANK SHELL AND HEADS: 1/4"  
 SECONDARY TANK SHELL: 7 GA HEADS: 1/4"

LABELING/MARKING: UNDERWRITERS LABORATORIES UL-142/STI F921

CUSTOMER:  
 PROJECT:  
 AGENT:



P.O. BOX 1279 GOLDSBORO, NC 27533  
 PHONE: (919)751-1791 FAX: (919)751-8186

DRAWING NUMBER: GIDH25K120 REVISED 7/14

QUANTITY: ONE (1) REQUIRED  
 WEIGHT: 29,750 lbs ± 10%

\*SADDLES ARE SEAL WELDED TO TANK

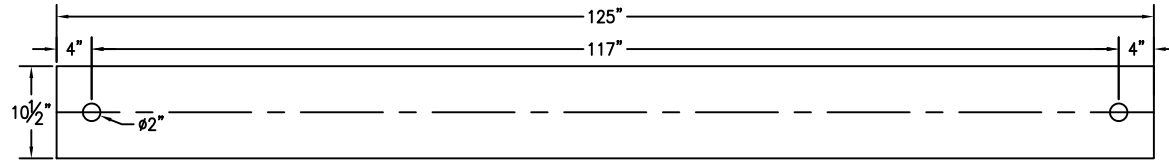

BASE PLATE ANCHOR HOLE DETAIL

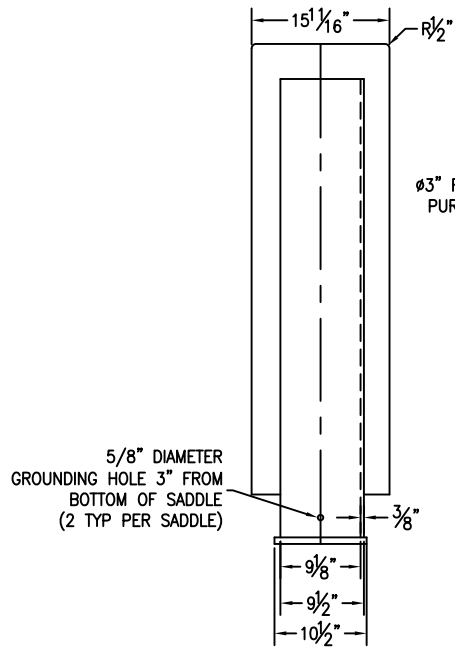

Ø3" FOR SHIPPING PURPOSES ONLY

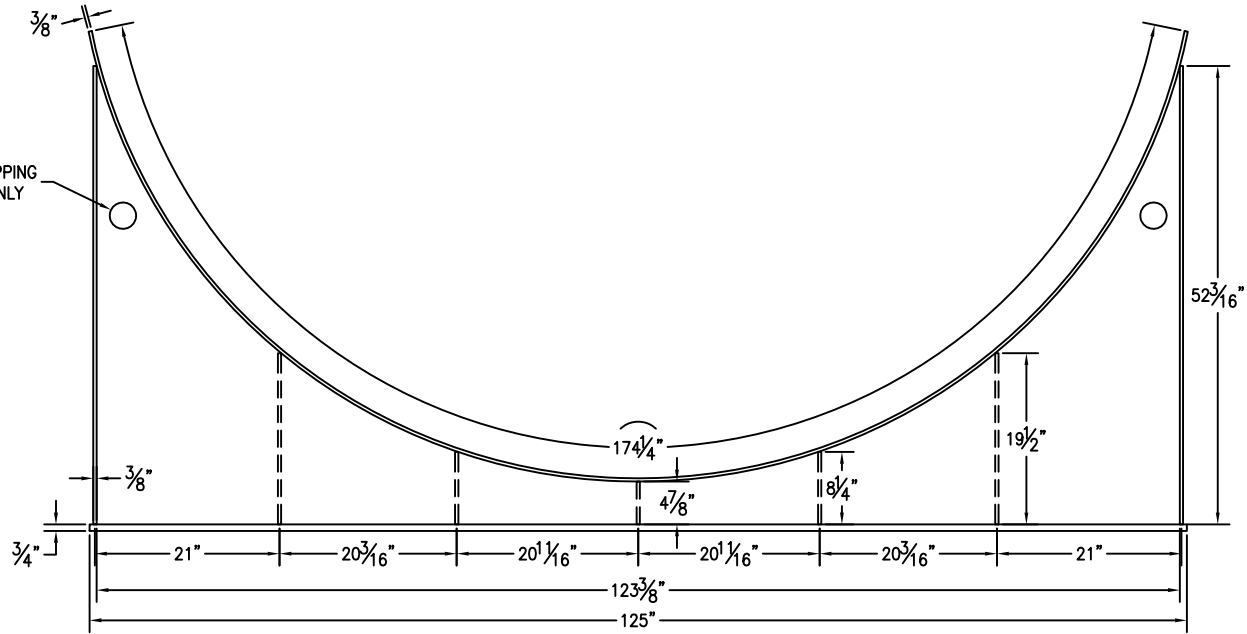

CUSTOMER APPROVAL SIGNATURE/DATE:

25,000 GAL 6" TALL SADDLE FOR 127" DIAMETER TANK

SURFACE PREPARATION/COATING INFORMATION:

MATERIAL /CONSTRUCTION/ LABELING INFORMATION:

EXTERIOR SURFACES: SSPC-SP-6 COMMERCIAL BLAST CLEAN  
5-7 MILS ALIPHATIC URETHANE (WHITE)

MATERIAL: CARBON STEEL ASTM A 36 OR A 569

CUSTOMER:  
PROJECT:  
AGENT:



P.O. BOX 1279 GOLDSBORO, NC 27533  
PHONE: (919)751-1791 FAX: (919)751-8186

DRAWING NUMBER: GI-S612725DW REVISED 7/14

QUANTITY: TWO (2) REQUIRED  
WEIGHT: 1,076 lb ± 10%