

*SADDLES ARE SEAL WELDED TO TANK

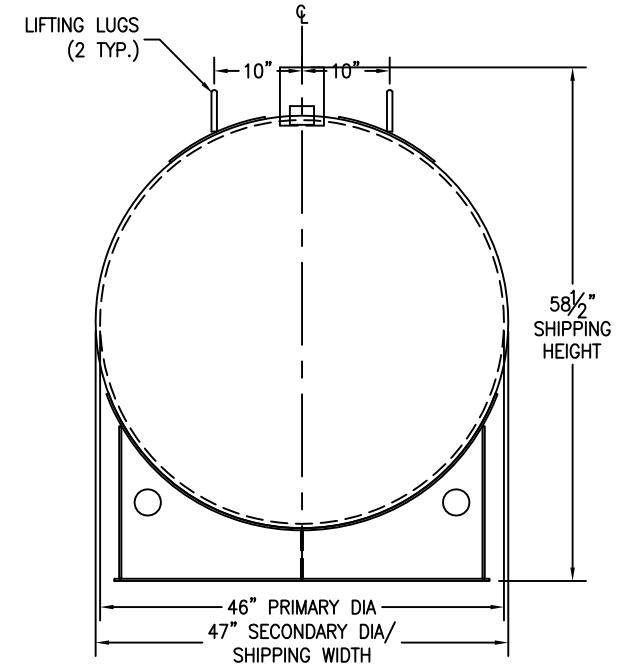

2" 90° LONG RADIUS ELBOW WITH
2" SCH. 40 PIPE AND 2" FNPT COUPLING
(INTERSTITIAL MONITOR / LEAK DETECTION
ACCESS)

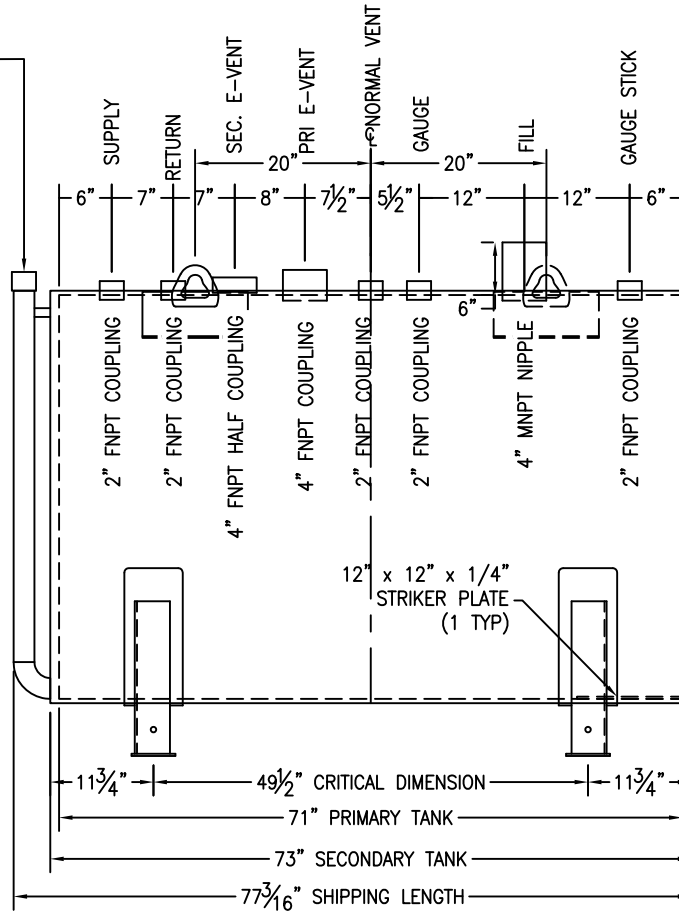

CUSTOMER APPROVAL SIGNATURE/DATE:

500 GALLON HORIZONTAL D/W ABOVE GROUND TANK

SURFACE PREPARATION/COATING INFORMATION:
 INTERIOR SURFACES: SSPC-SP-3 POWER TOOL CLEAN WELDS ONLY
 REMOVE ALL LOOSE DEBRIS
 EXTERIOR SURFACES: SSPC-SP-6 COMMERCIAL BLAST
 5-7 MILS ALIPHATIC URETHANE (WHITE)

MATERIAL /CONSTRUCTION/ LABELING INFORMATION:
 MATERIAL: CARBON STEEL ASTM A 36 OR A 569
 MATERIAL THICKNESS: PRIMARY TANK SHELL AND HEADS: 10 GA
 SECONDARY TANK SHELL AND HEADS: 10 GA

LABELING/MARKING: UNDERWRITERS LABORATORIES UL-142/STI F921

CUSTOMER:
 PROJECT:
 AGENT:



P.O. BOX 1279 GOLDSBORO, NC 27533
 PHONE: (919)751-1791 FAX: (919)751-8186
 DRAWING NUMBER: GIDH50046

REVISED 7/14

QUANTITY: ONE (1) REQUIRED
 WEIGHT: 1,500 lbs ± 10%

*SADDLES ARE SEAL WELDED TO TANK

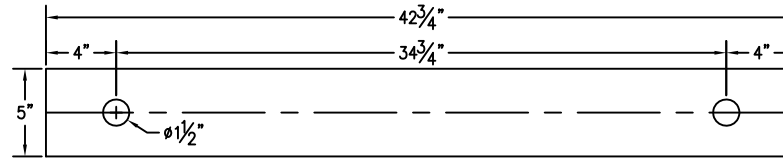

BASE PLATE ANCHOR HOLE DETAIL

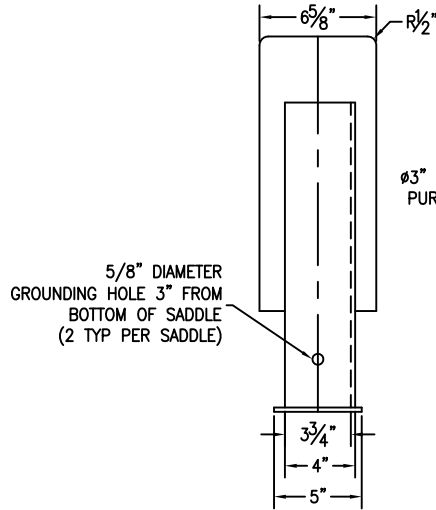

5/8" DIAMETER
GROUNDING HOLE 3" FROM
BOTTOM OF SADDLE
(2 TYP PER SADDLE)

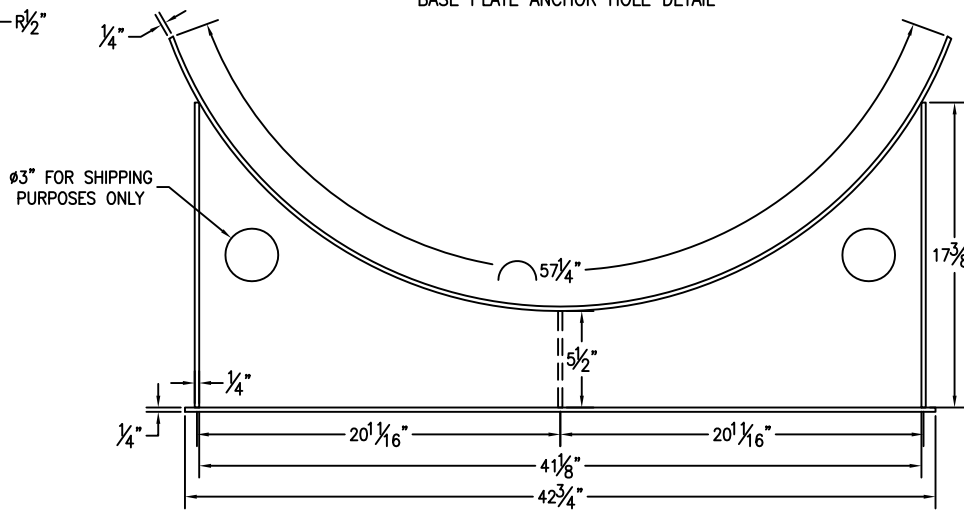

Ø3" FOR SHIPPING
PURPOSES ONLY

CUSTOMER APPROVAL SIGNATURE/DATE:

500 GAL 6" TALL SADDLE FOR 47" DIAMETER TANK

SURFACE PREPARATION/COATING INFORMATION:

MATERIAL /CONSTRUCTION/ LABELING INFORMATION:

EXTERIOR SURFACES: SSPC-SP-6 COMMERCIAL BLAST
5-7 MILS ALIPHATIC URETHANE (WHITE)

MATERIAL: CARBON STEEL ASTM A 36 OR A 569

CUSTOMER:

PROJECT:

AGENT:



P.O. BOX 1279 GOLDSBORO, NC 27533
PHONE: (919)751-1791 FAX: (919)751-8186

DRAWING NUMBER:
GI-S6047500DW

REVISED 7/14

QUANTITY: TWO (2) REQUIRED
WEIGHT: 96 lb ea ± 10%