

\*SADDLES ARE SEAL WELDED TO TANK

MORRISON 244OF 8"  
EMERGENCY VENT SHIPPED  
LOOSE DUE TO SHIPPING  
HEIGHT RESTRICTIONS

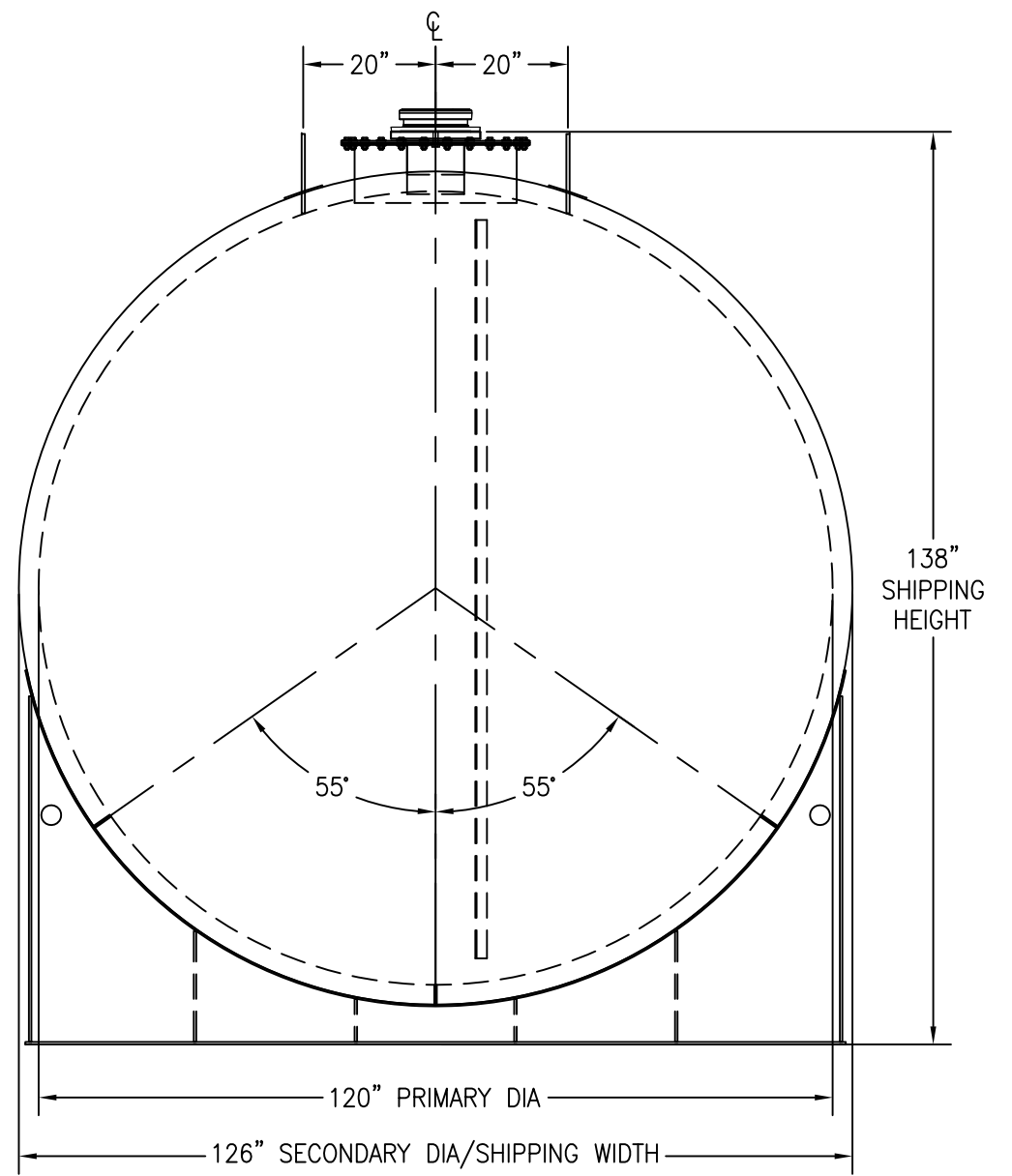

2" FNPT FITTING (PERLITE  
FILL / INSPECTION)  
2" PIPE W/ FNPT COUPLING  
(INTERSTITIAL MONITOR PORT)

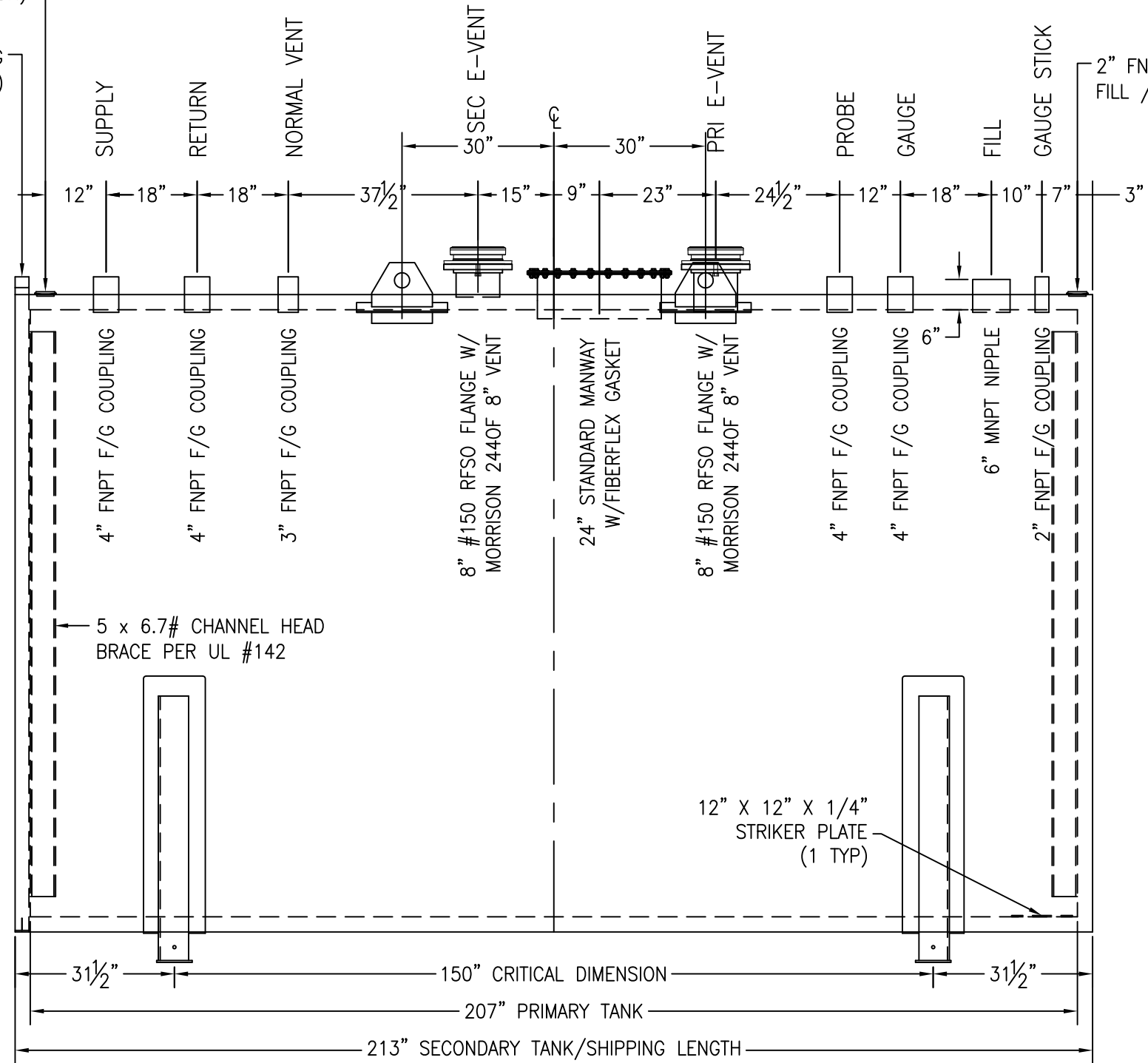

CUSTOMER APPROVAL SIGNATURE/DATE:

**10,000 GALLON THERMALLY INSULATED (FIREGUARD) STORAGE TANK**

**SURFACE PREPARATION/COATING INFORMATION:**  
 INTERIOR SURFACES: SSPC-SP-3 POWER TOOL CLEAN WELDS ONLY  
 REMOVE ALL LOOSE DEBRIS  
 EXTERIOR SURFACES: SSPC-SP-6 COMMERCIAL BLAST  
 ONE COAT WHITE URETHANE @ 5-7 MILS DFT

**MATERIAL /CONSTRUCTION/ LABELING INFORMATION:**  
 MATERIAL: CARBON STEEL ASTM A 36 OR A 569  
 MATERIAL THICKNESS: PRIMARY SHELL: 1/4" PRIMARY HEADS: 1/4"  
 SECONDARY SHELL: 1/4" SECONDARY HEADS: 5/16"

CUSTOMER:  
 PROJECT:  
 AGENT:



QUANTITY: ONE (1) REQUIRED  
 WEIGHT WITHOUT PERLITE: 18,000 lbs ± 10%  
 WEIGHT: 25,250 lbs ± 10%

LABELING/MARKING: UNDERWRITERS LABORATORIES UL-2085  
 / STEEL TANK INSTITUTE FIREGUARD

P.O. BOX 1279 GOLDSBORO, NC 27533  
 PHONE: (919)751-1791 FAX: (919)751-8186  
 DRAWING NUMBER: GIFG10K120  
 REVISED 6/15

\*SADDLES ARE SEAL WELDED TO TANK

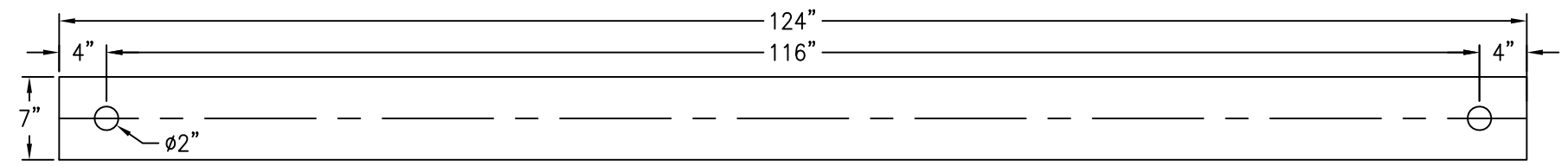

BASE PLATE ANCHOR HOLE DETAIL

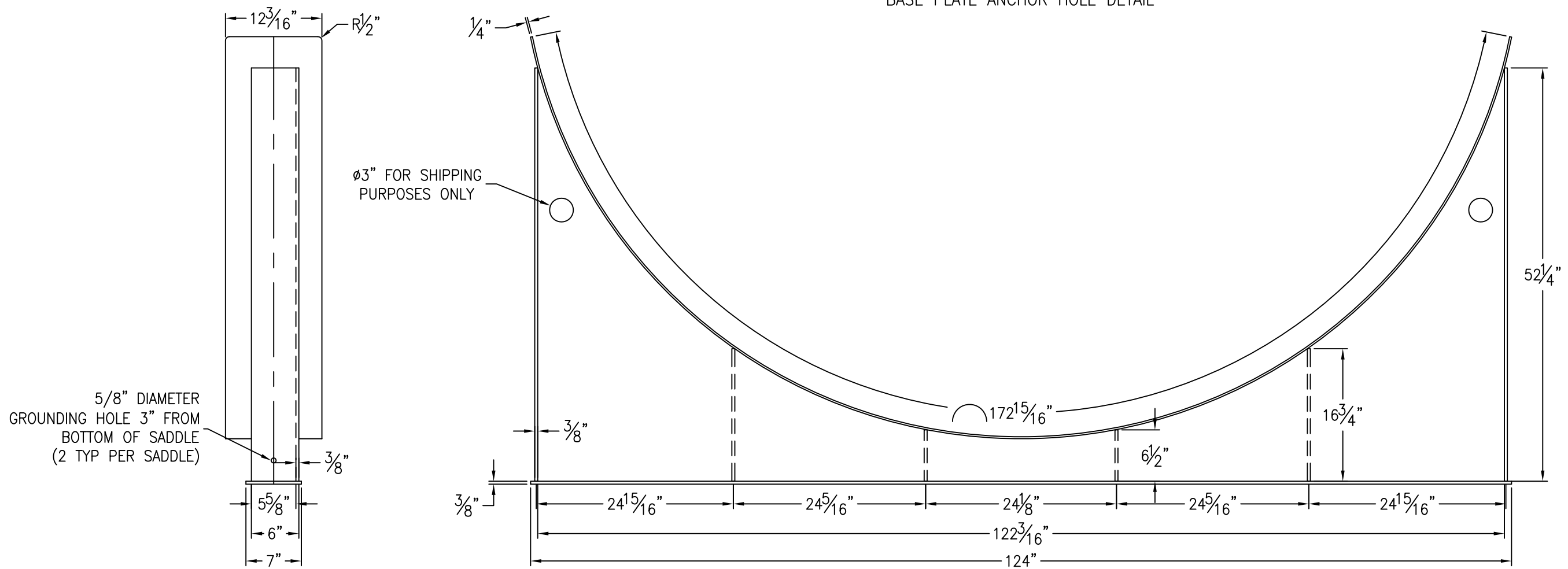

5/8" DIAMETER GROUNDING HOLE 3" FROM BOTTOM OF SADDLE (2 TYP PER SADDLE)

Ø3" FOR SHIPPING PURPOSES ONLY

CUSTOMER APPROVAL SIGNATURE/DATE:

10,000 GAL 6" TALL SADDLE FOR 126" DIAMETER FIREGUARD TANK

SURFACE PREPARATION/COATING INFORMATION:

MATERIAL /CONSTRUCTION/ LABELING INFORMATION:

EXTERIOR SURFACES: SSPC-SP-6 COMMERCIAL BLAST  
ONE COAT WHITE URETHANE @ 5-7 MILS DFT

MATERIAL: CARBON STEEL ASTM A 36 OR A 569

CUSTOMER:  
PROJECT:  
AGENT:



P.O. BOX 1279 GOLDSBORO, NC 27533  
PHONE: (919)751-1791 FAX: (919)751-8186

DRAWING NUMBER: GI-S6F12610 REVISED 6/15

QUANTITY: TWO (2) REQUIRED  
WEIGHT: 713 lbs ea ± 10%