

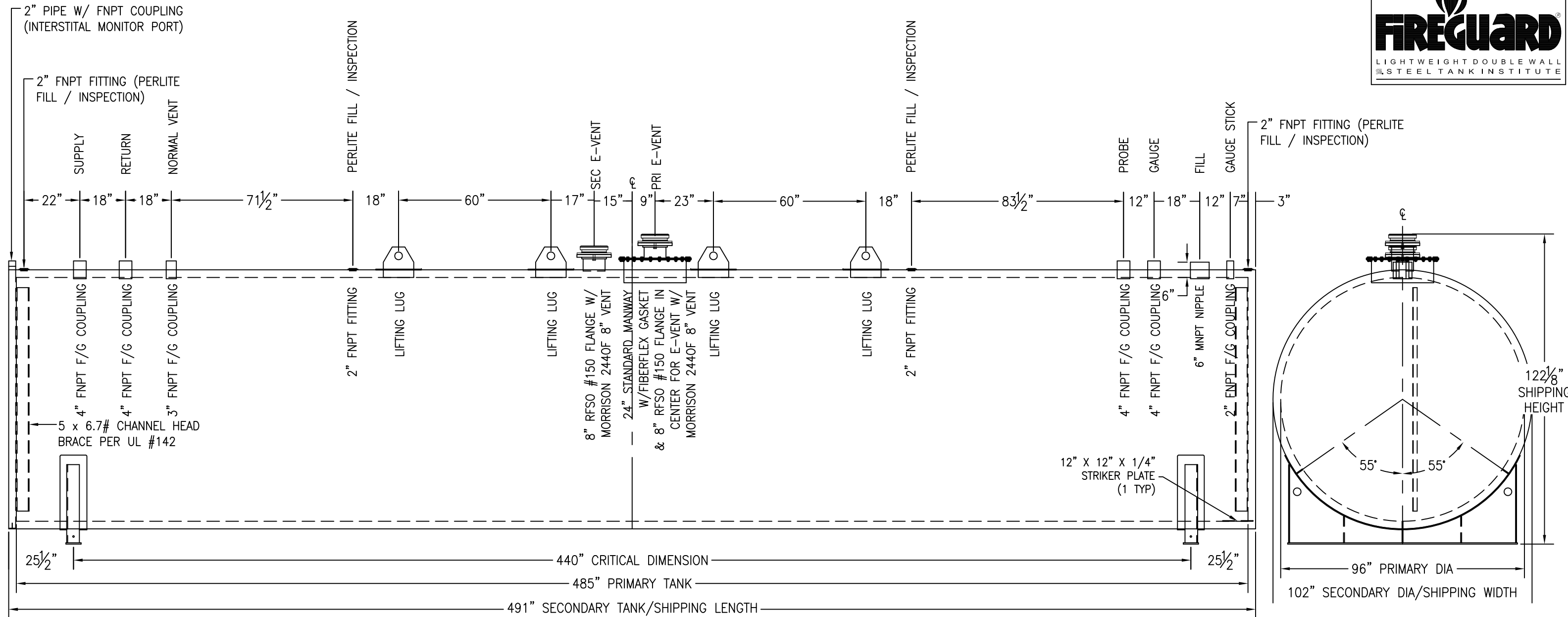

*SADDLES ARE SEAL WELDED TO TANK



CUSTOMER APPROVAL SIGNATURE/DATE:

15,000 GALLON THERMALLY INSULATED (FIREGUARD) STORAGE TANK

SURFACE PREPARATION/COATING INFORMATION:
 INTERIOR SURFACES: SSPC-SP-3 POWER TOOL CLEAN WELDS ONLY
 REMOVE ALL LOOSE DEBRIS
 EXTERIOR SURFACES: SSPC-SP-6 COMMERCIAL BLAST
 ONE COAT WHITE URETHANE @ 5-7 MILS DFT

MATERIAL /CONSTRUCTION/ LABELING INFORMATION:
 MATERIAL: CARBON STEEL ASTM A 36 OR A 569
 MATERIAL THICKNESS: PRIMARY TANK: 1/4" PRIMARY HEADS: 1/4"
 SECONDARY TANK: 1/4" SECONDARY HEADS: 5/16"

CUSTOMER:
 PROJECT:
 AGENT:



P.O. BOX 1279 GOLDSBORO, NC 27533
 PHONE: (919)751-1791 FAX: (919)751-8186

QUANTITY: ONE (1) REQUIRED
 WEIGHT WITHOUT PERLITE: 26,250 lbs ± 10%
 WEIGHT: 37,500 lbs ± 10%

LABELING/MARKING: UNDERWRITERS LABORATORIES UL-2085
 / STEEL TANK INSTITUTE FIREGUARD

DRAWING NUMBER: GIFG15K96
 REVISED 6/15

*SADDLES ARE SEAL WELDED TO TANK

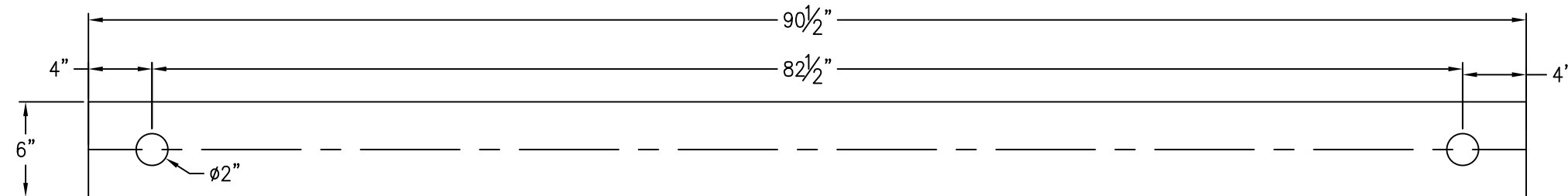

BASE PLATE ANCHOR HOLE DETAIL

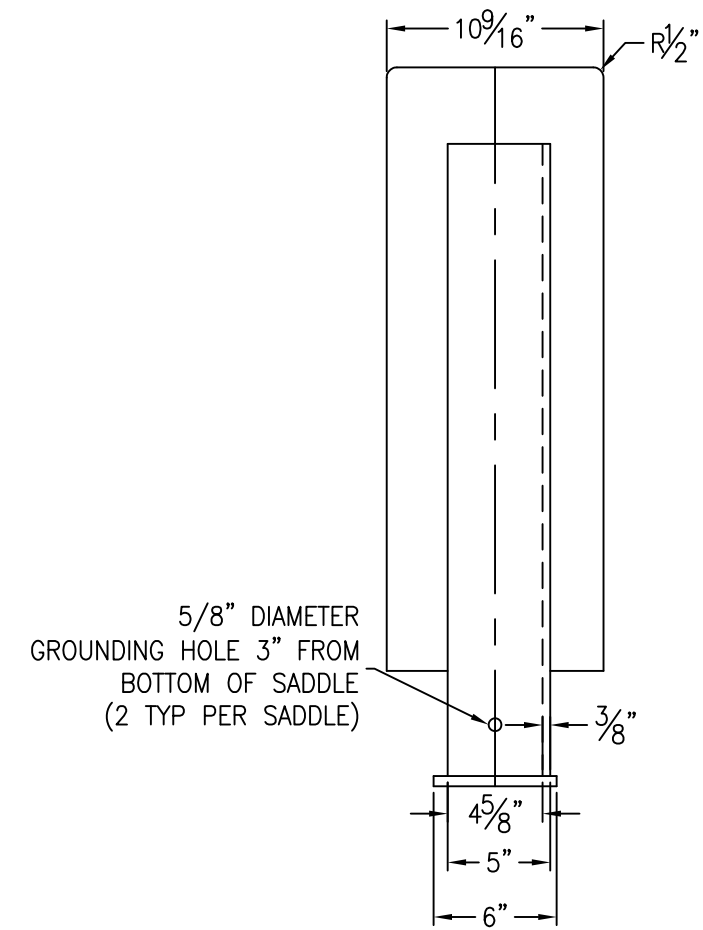

ø3" FOR SHPPING PURPOSES ONLY

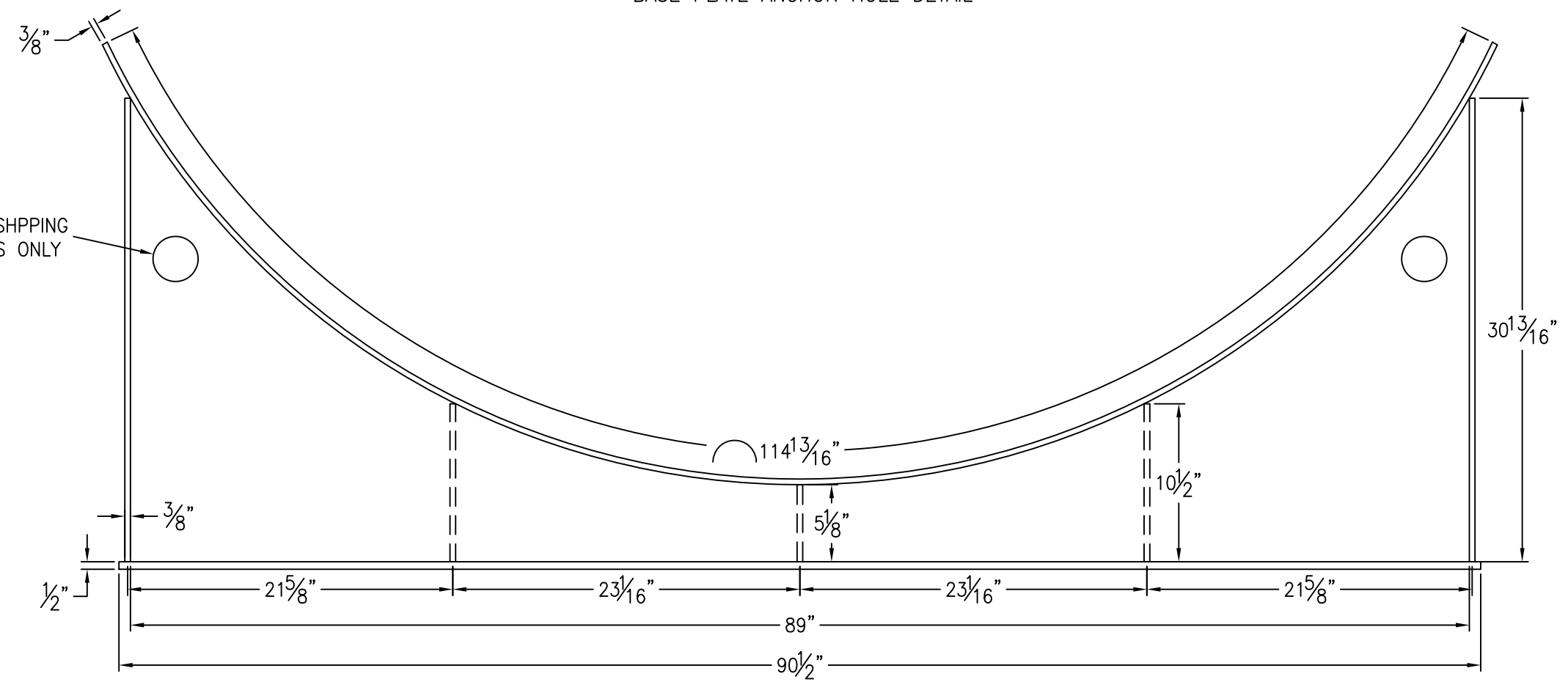

CUSTOMER APPROVAL SIGNATURE/DATE:

15,000 GAL 6" TALL SADDLE FOR 102" DIAMETER FIREGUARD TANK

SURFACE PREPARATION/COATING INFORMATION:

MATERIAL /CONSTRUCTION/ LABELING INFORMATION:

EXTERIOR SURFACES: SSPC-SP-6 COMMERCIAL BLAST
ONE COAT WHITE URETHANE @ 5-7 MILS DFT

MATERIAL: CARBON STEEL ASTM A 36 OR A 569

CUSTOMER:
PROJECT:
AGENT:



P.O. BOX 1279 GOLDSBORO, NC 27533
PHONE: (919)751-1791 FAX: (919)751-8186

DRAWING NUMBER: GI-S6F10215
REVISED 6/15

QUANTITY: TWO (2) REQUIRED
WEIGHT: 427 lbs ea ± 10%