

*SADDLES ARE SEAL WELDED TO TANK

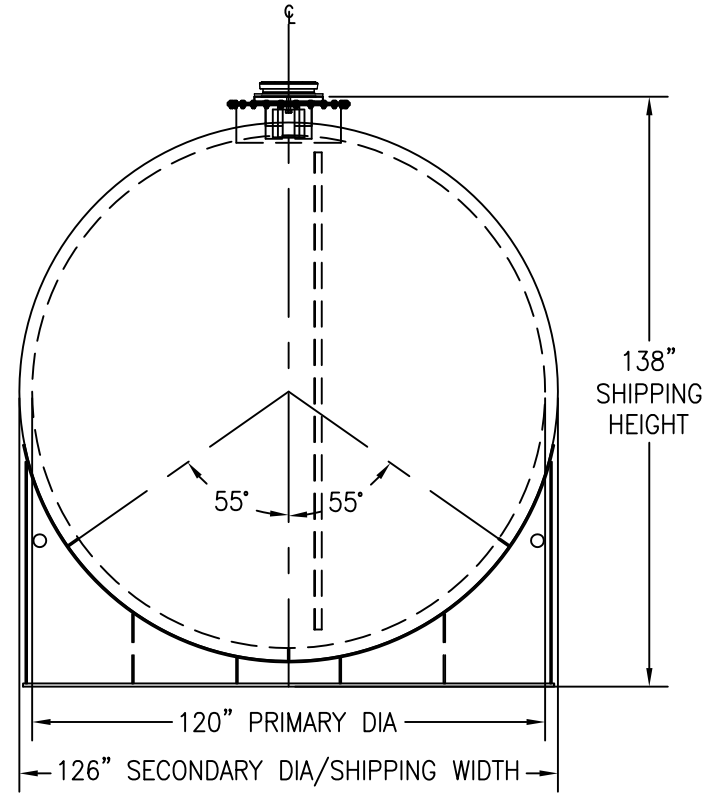

MORRISON 244OF 10"
EMERGENCY VENT SHIPPED
LOOSE DUE TO SHIPPING
HEIGHT RESTRICTIONS

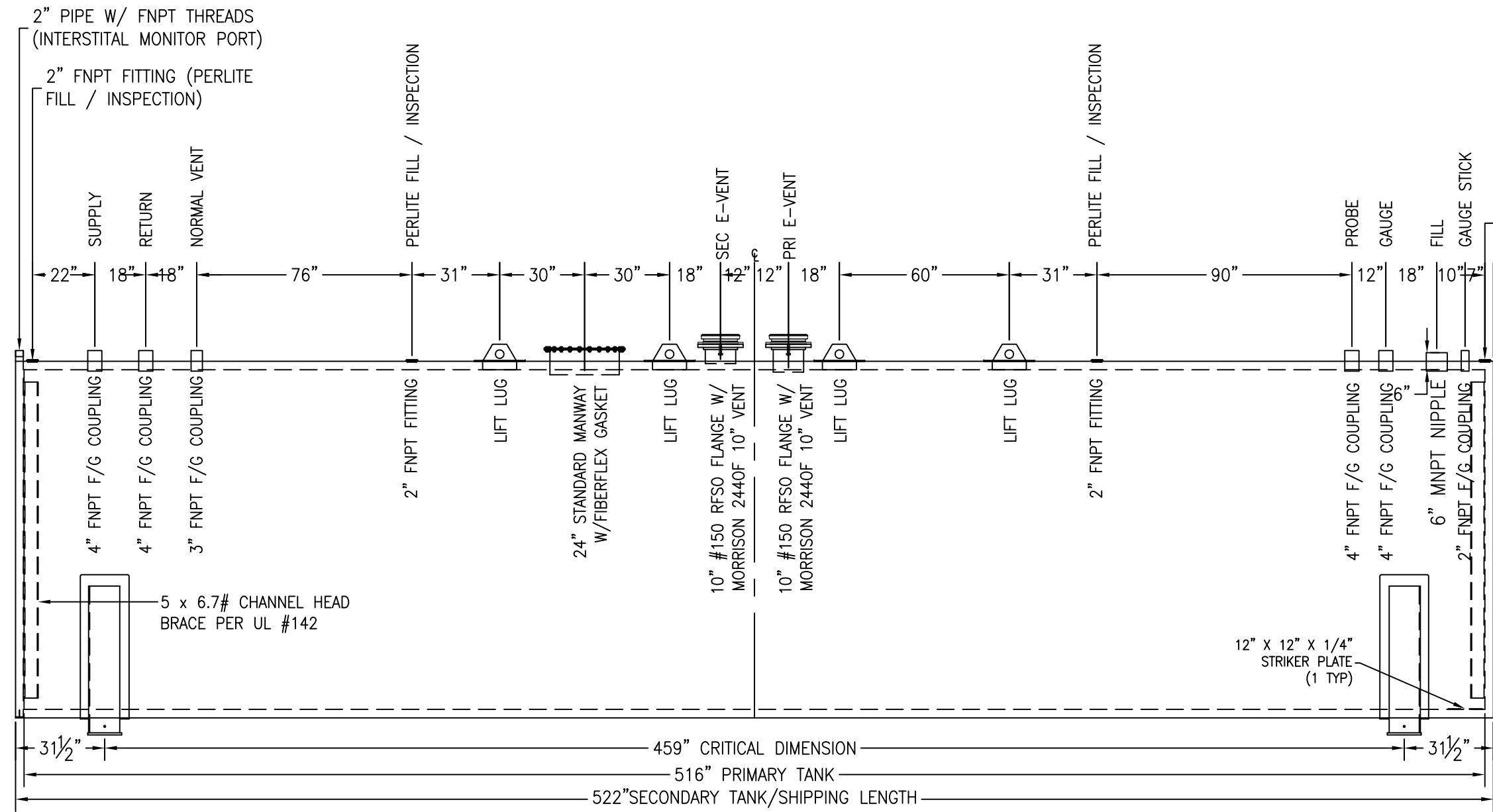

CUSTOMER APPROVAL SIGNATURE/DATE:

25,000 GALLON THERMALLY INSULATED (FIREGUARD) STORAGE TANK

SURFACE PREPARATION/COATING INFORMATION:
 INTERIOR SURFACES: SSPC-SP-3 POWER TOOL CLEAN WELDS ONLY
 REMOVE ALL LOOSE DEBRIS
 EXTERIOR SURFACES: SSPC-SP-6 COMMERCIAL BLAST
 ONE COAT WHITE URETHANE @ 5-7 MILS DFT

MATERIAL /CONSTRUCTION/ LABELING INFORMATION:
 MATERIAL: CARBON STEEL ASTM A 36 OR A 569
 MATERIAL THICKNESS: PRIMARY SHELL: 1/4" PRIMARY HEADS: 1/4"
 SECONDARY SHELL: 1/4" SECONDARY HEADS: 5/16"

QUANTITY: ONE (1) REQUIRED
 WEIGHT WITHOUT PERLITE: 36,000 lbs ± 10%
 WEIGHT: 51,250 lbs ± 10%

LABELING/MARKING: UNDERWRITERS LABORATORIES UL-2085
 / STEEL TANK INSTITUTE FIREGUARD

CUSTOMER:
 PROJECT:
 AGENT:
GENERAL INDUSTRIES
 P.O. BOX 1279 GOLDSBORO, NC 27533
 PHONE: (919)751-1791 FAX: (919)751-8186
 DRAWING NUMBER: **GIFG25K120** REVISED 6/15

*SADDLES ARE SEAL WELDED TO TANK

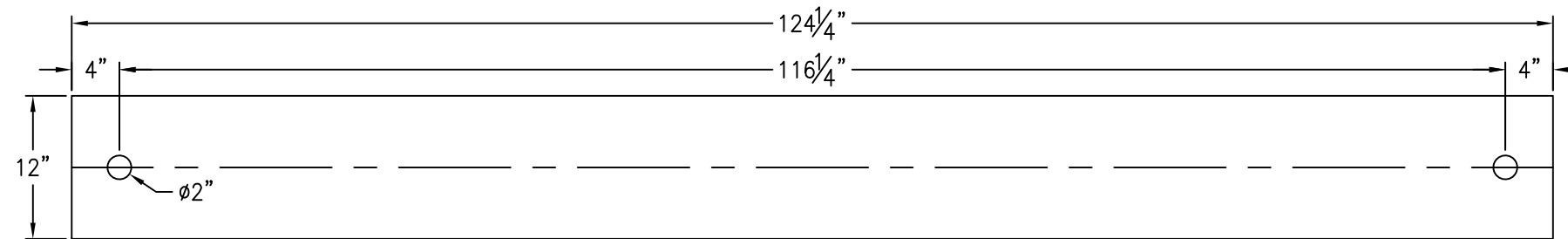

BASE PLATE ANCHOR HOLE DETAIL

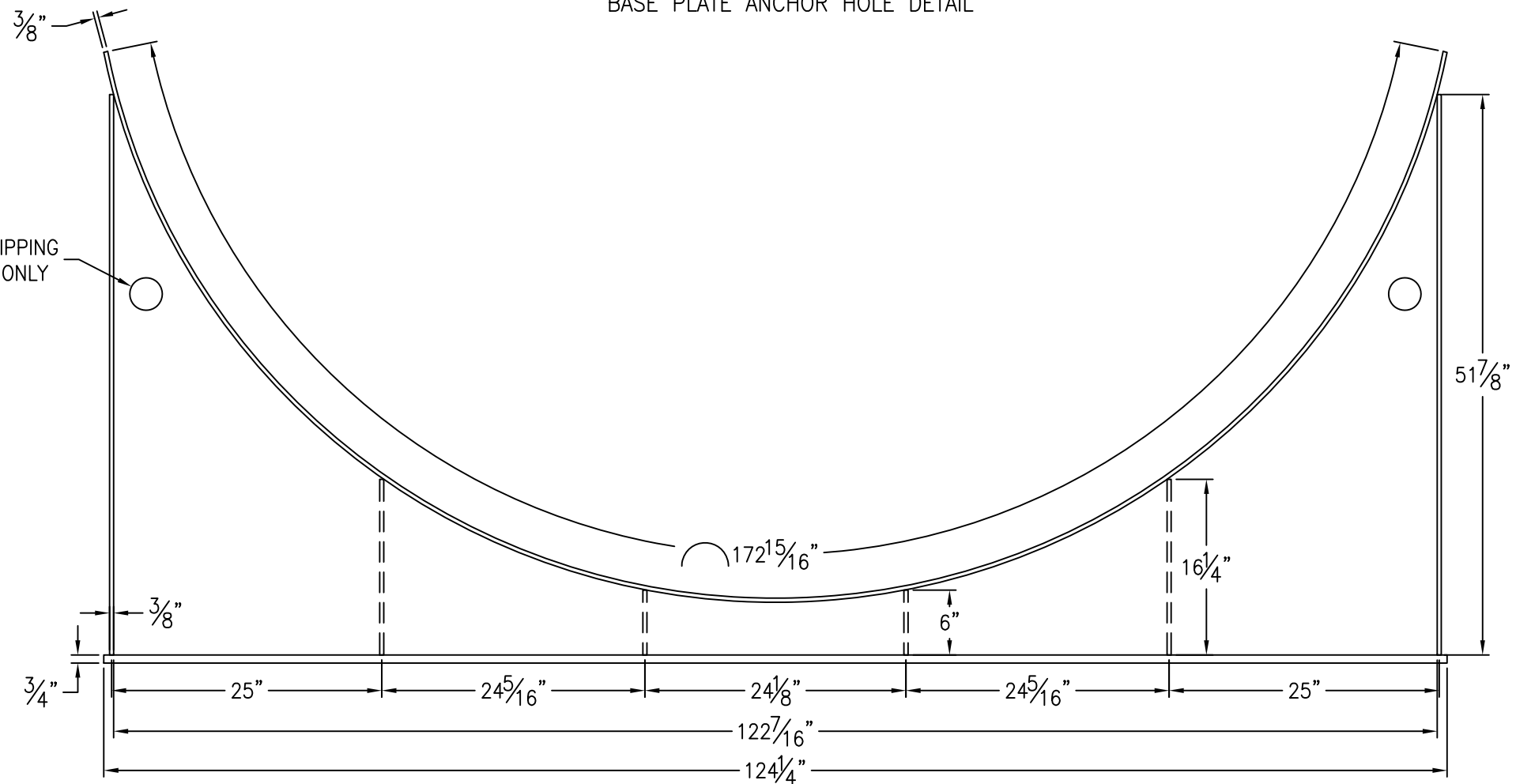
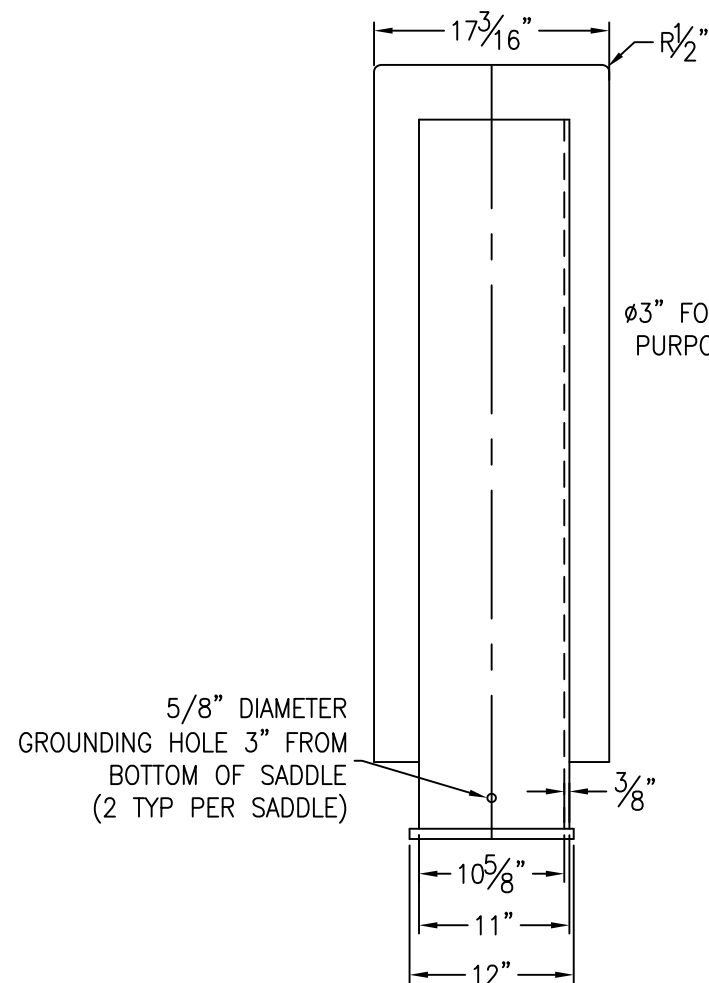

Ø3" FOR SHIPPING PURPOSES ONLY

5/8" DIAMETER GROUNDING HOLE 3" FROM BOTTOM OF SADDLE (2 TYP PER SADDLE)

CUSTOMER APPROVAL SIGNATURE/DATE:

25,000 GAL 6" TALL SADDLE FOR 126 DIAMETER FIREGUARD TANK

SURFACE PREPARATION/COATING INFORMATION:

EXTERIOR SURFACES: SSPC-SP-6 COMMERCIAL BLAST
ONE COAT WHITE URETHANE @ 5-7 MILS DFT

MATERIAL /CONSTRUCTION/ LABELING INFORMATION:

MATERIAL: CARBON STEEL ASTM A 36 OR A 569

CUSTOMER:

PROJECT:

AGENT:



P.O. BOX 1279 GOLDSBORO, NC 27533
PHONE: (919)751-1791 FAX: (919)751-8186

DRAWING NUMBER:
GI-S6F12626

REVISED 6/15

QUANTITY: TWO (2) REQUIRED
WEIGHT: 1,180 lbs ea ± 10%