

*SADDLES ARE SEAL WELDED TO TANK

2" 90° LONG RADIUS ELBOW / 2" SCH. 40 PIPE AND 2" FNPT COUPLING
(INTERSTITIAL MONITOR / LEAK DETECTION)

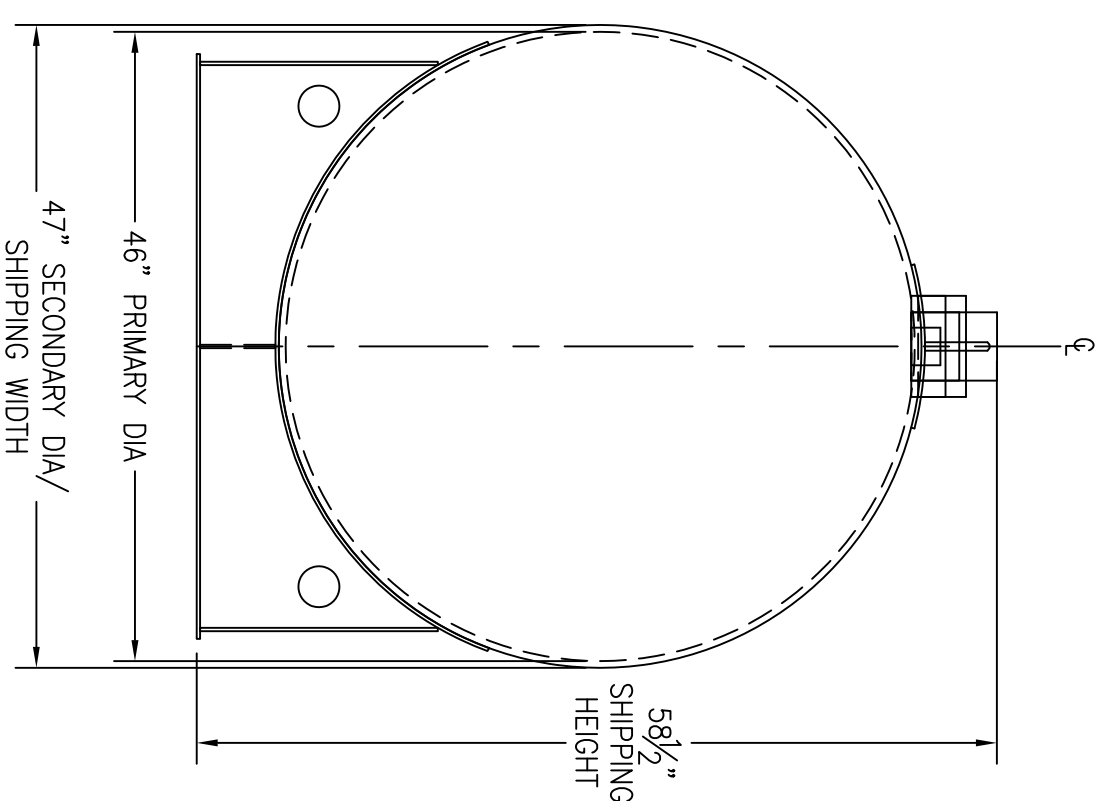
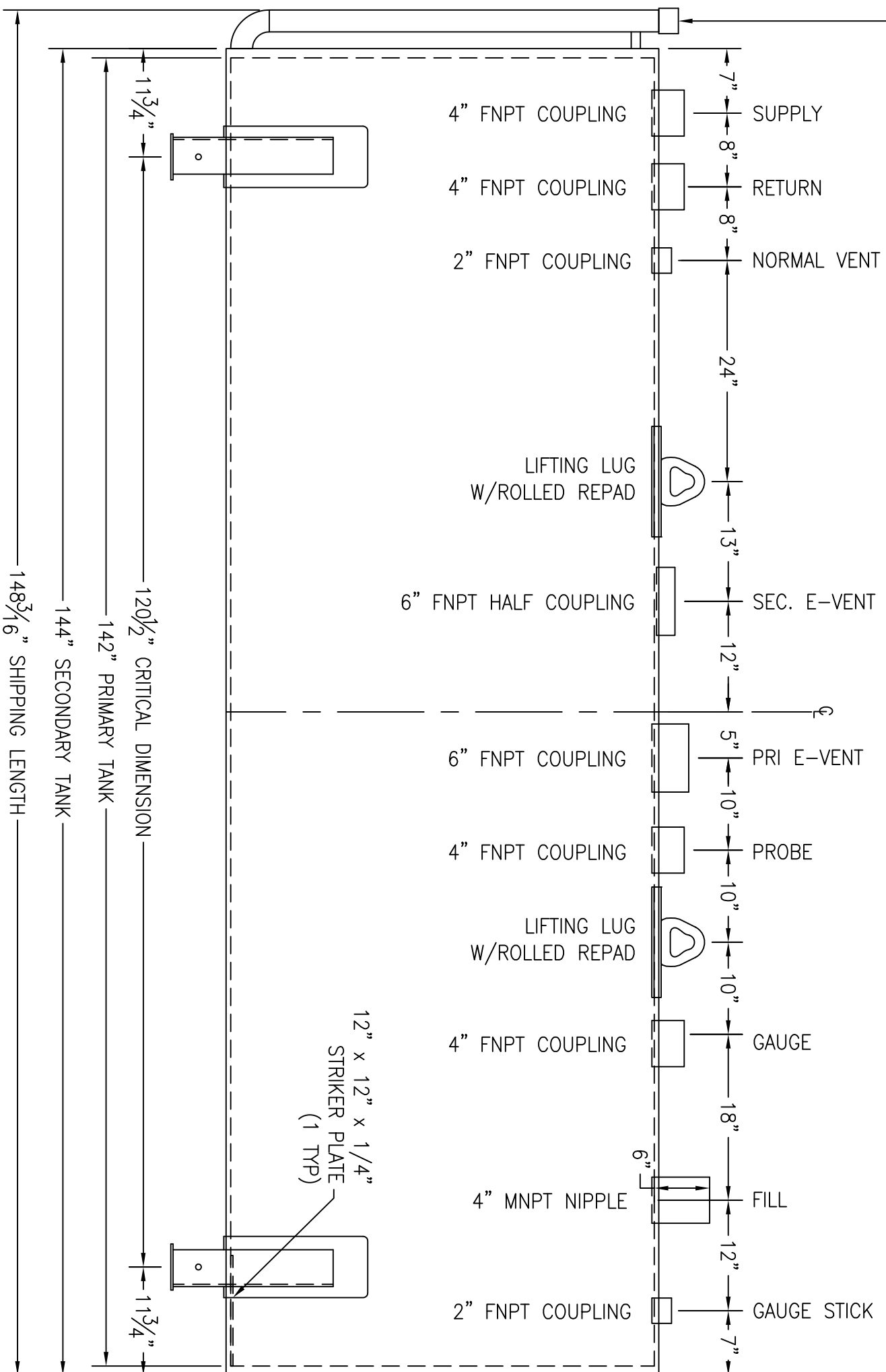

CUSTOMER APPROVAL SIGNATURE/DATE:

1,000 GALLON HORIZONTAL DW ABOVE GROUND TANK

SURFACE PREPARATION/COATING INFORMATION:

INTERIOR SURFACES: SSPC-SP-3 POWER TOOL CLEAN WELDS ONLY
REMOVE ALL LOOSE DEBRIS
EXTERIOR SURFACES: SSPC-SP-6 COMMERCIAL BLAST
5-7 MILS ALIPHATIC URETHANE (WHITE)

MATERIAL /CONSTRUCTION/ LABELING INFORMATION:

MATERIAL: CARBON STEEL ASTM A 36 OR A 569
MATERIAL THICKNESS: PRIMARY TANK SHELL AND HEADS: 10 GA
SECONDARY TANK SHELL AND HEADS: 10 GA

LABELING/MARKING: UNDERWRITERS LABORATORIES UL-142/STI F921

CUSTOMER:
PROJECT:

AGENT:



P.O. BOX 1279 GOLDSBORO, NC 27533
PHONE: (919)751-1791 FAX: (919)751-8186
DRAWING NUMBER: GIDH01K46 REVISED 7/14

QUANTITY: ONE (1) REQUIRED
WEIGHT: 3,250 lbs ± 10%

