

\*SADDLES ARE SEAL WELDED TO TANK

2" 90° LONG RADIUS ELBOW WITH 2" SCH. 40 PIPE AND 2" FNPT COUPLING (INTERSTITIAL MONITOR / LEAK DETECTION ACCESS)

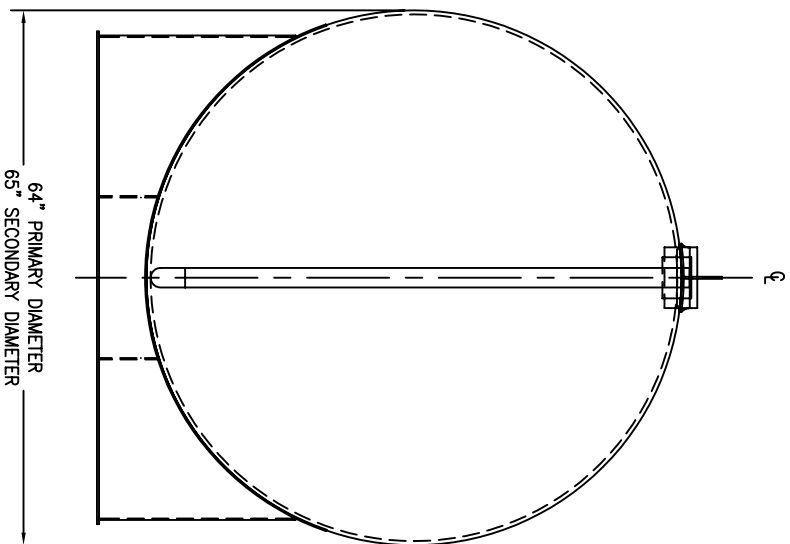
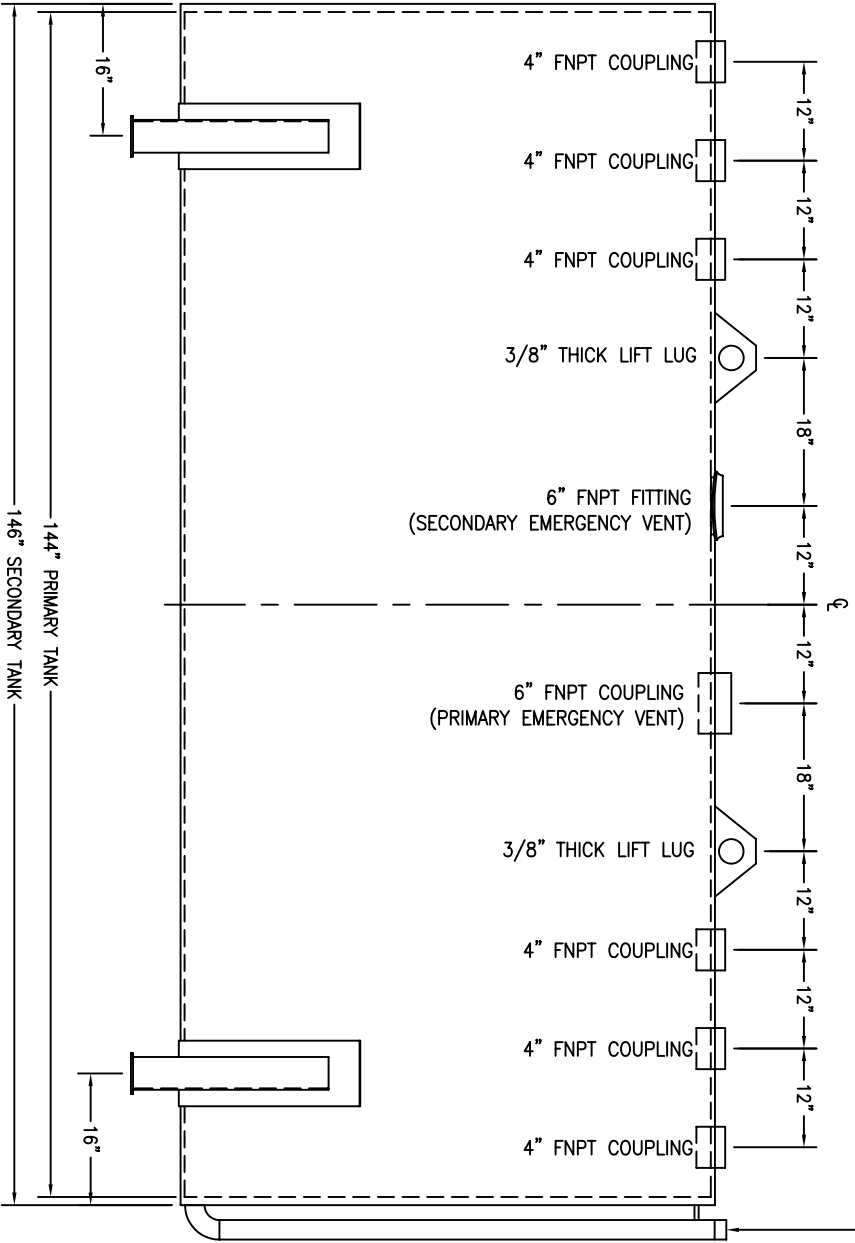

CUSTOMER APPROVAL SIGNATURE/DATE:

2,000 GALLON HORIZONTAL FLAMESHIELD D/W ABOVE GROUND TANK

SURFACE PREPARATION/COATING INFORMATION:

INTERIOR SURFACES: N/A  
 EXTERIOR SURFACES: SSPC-SP-6 COMMERCIAL BLAST CLEAN  
 ONE COAT EPOXY PRIMER @ 4mils DFT  
 ONE COAT WHITE URETHANE @ 6mils DFT

MATERIAL /CONSTRUCTION/ LABELING INFORMATION:

MATERIAL: CARBON STEEL (ASTM A 36, ASTM A 635 OR ASTM A 569)  
 MATERIAL THICKNESS: PRIMARY TANK SHELL AND HEADS: 7 GA  
 SECONDARY TANK SHELL AND HEADS: 10 GA  
 CONSTRUCTION IN ACCORDANCE WITH UNDERWRITERS LABORATORIES UL-142 / SJI F--921  
 STANDARDS FOR STEEL ABOVEGROUND TANKS FOR FLAMMABLE AND COMBUSTIBLE LIQUIDS  
 LABELING/MARKING: UNDERWRITERS LABORATORIES UL-142 /  
 GENERAL INDUSTRIES NAMEPLATE

QUANTITY: ONE (1) REQUIRED  
 WEIGHT: 0 lbs ± 5%

Steel Tank Institute  
**STI** Institute  
 FLAMESHIELD

CUSTOMER: \_\_\_\_\_  
 PROJECT: \_\_\_\_\_  
 AGENT: \_\_\_\_\_

**GENERAL INDUSTRIES**  
 BUILDERS OF TANKS  
 OIL TANKS / CHEMICAL TANKS / PROJECT

P.O. BOX 1279 GOLDSPORO, NC 27533  
 PHONE NUMBER: (919) 751-1791 FAX: (919) 751-8188  
 DRAWING NUMBER: \_\_\_\_\_