

*SADDLES ARE SEAL WELDED TO TANK

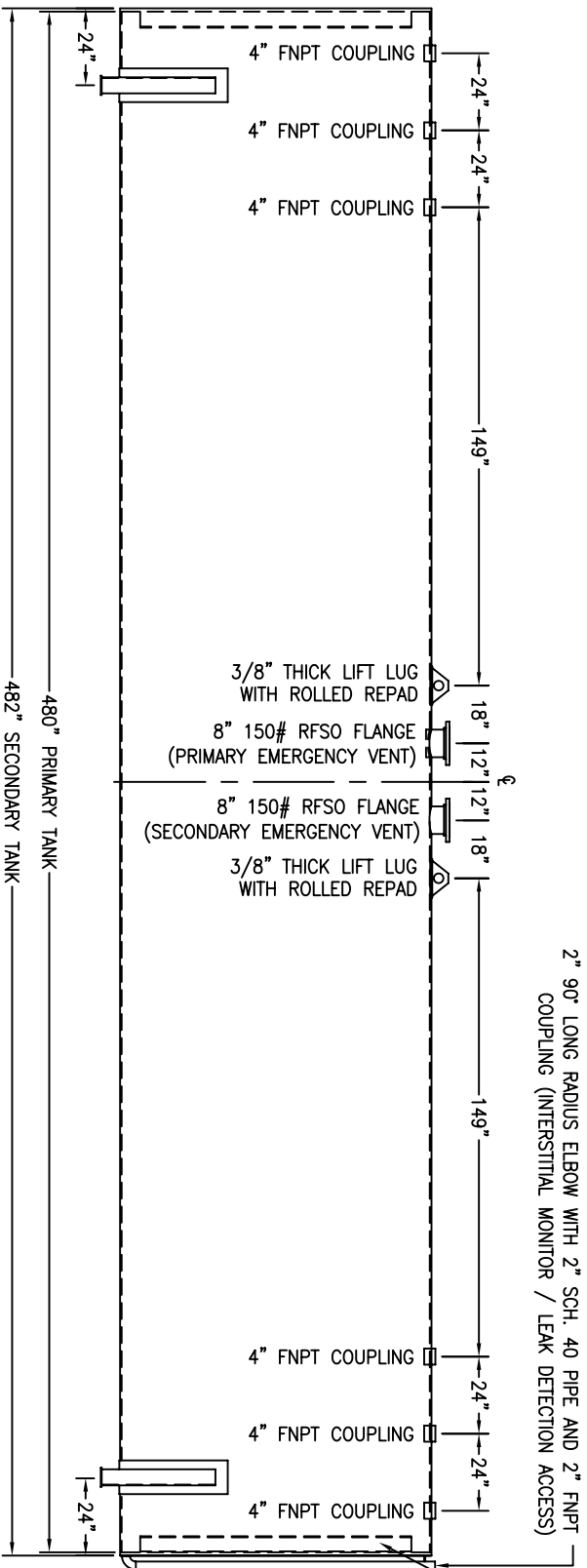

2" 90° LONG RADIUS ELBOW WITH 2" SCH. 40 PIPE AND 2" FNPT COUPLING (INTERSTITIAL MONITOR / LEAK DETECTION ACCESS)

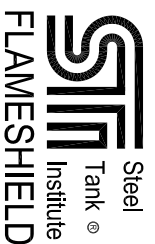
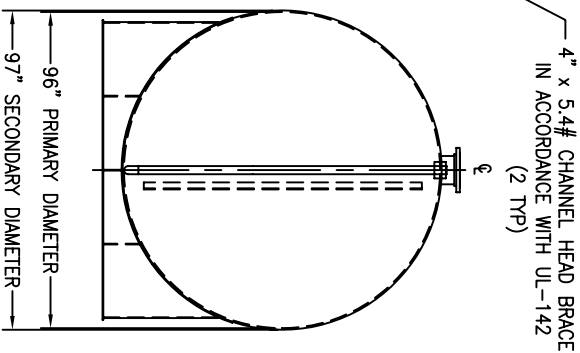

CUSTOMER APPROVAL SIGNATURE/DATE:

15,000 GALLON HORIZONTAL FLAMESHIELD DW ABOVE GROUND TANK

SURFACE PREPARATION/COATING INFORMATION:

INTERIOR SURFACES: N/A
 EXTERIOR SURFACES: SSPC-SP-6 COMMERCIAL BLAST CLEAN
 ONE COAT EPOXY PRIMER @ 4mils DFT
 ONE COAT WHITE URETHANE @ 6mils DFT

MATERIAL /CONSTRUCTION/ LABELING INFORMATION:

MATERIAL: CARBON STEEL (ASTM A 36, ASTM A 635 OR ASTM A 569)
 MATERIAL THICKNESS: PRIMARY TANK SHELL AND HEADS: 1/4"
 SECONDARY TANK SHELL AND HEADS: 7 GA
 CONSTRUCTION IN ACCORDANCE WITH UNDERWRITERS LABORATORIES UL-142 / SJI F-921
 STANDARDS FOR STEEL ABOVEGROUND TANKS FOR FLAMMABLE AND COMBUSTIBLE LIQUIDS
 LABELING/MARKING: UNDERWRITERS LABORATORIES UL-142 / GENERAL INDUSTRIES NAMEPLATE

QUANTITY: ONE (1) REQUIRED
 WEIGHT: 0 lbs ± 5%

CUSTOMER: _____
 PROJECT: _____
 AGENT: _____

GENERAL INDUSTRIES
 BUILDERS OF TANKS AND EQUIPMENT
 P.O. BOX 1279 GOLDSPORO, NC 27533
 PHONE: (919) 751-1791 FAX: (919) 751-8188
 DRAWING NUMBER: _____