

\*SADDLES ARE SEAL WELDED TO TANK

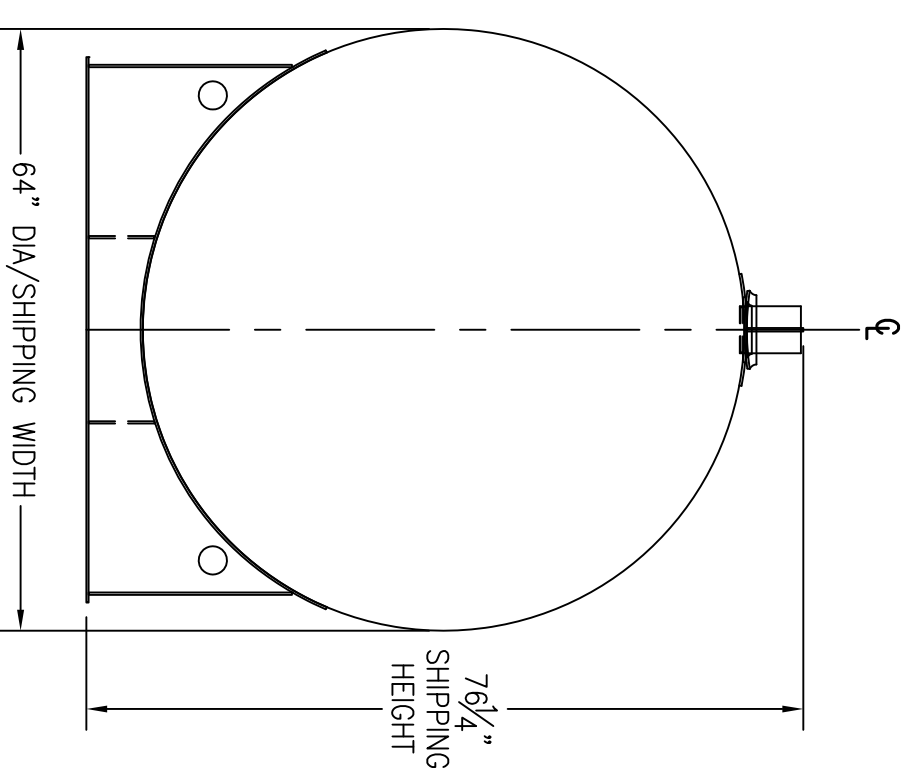
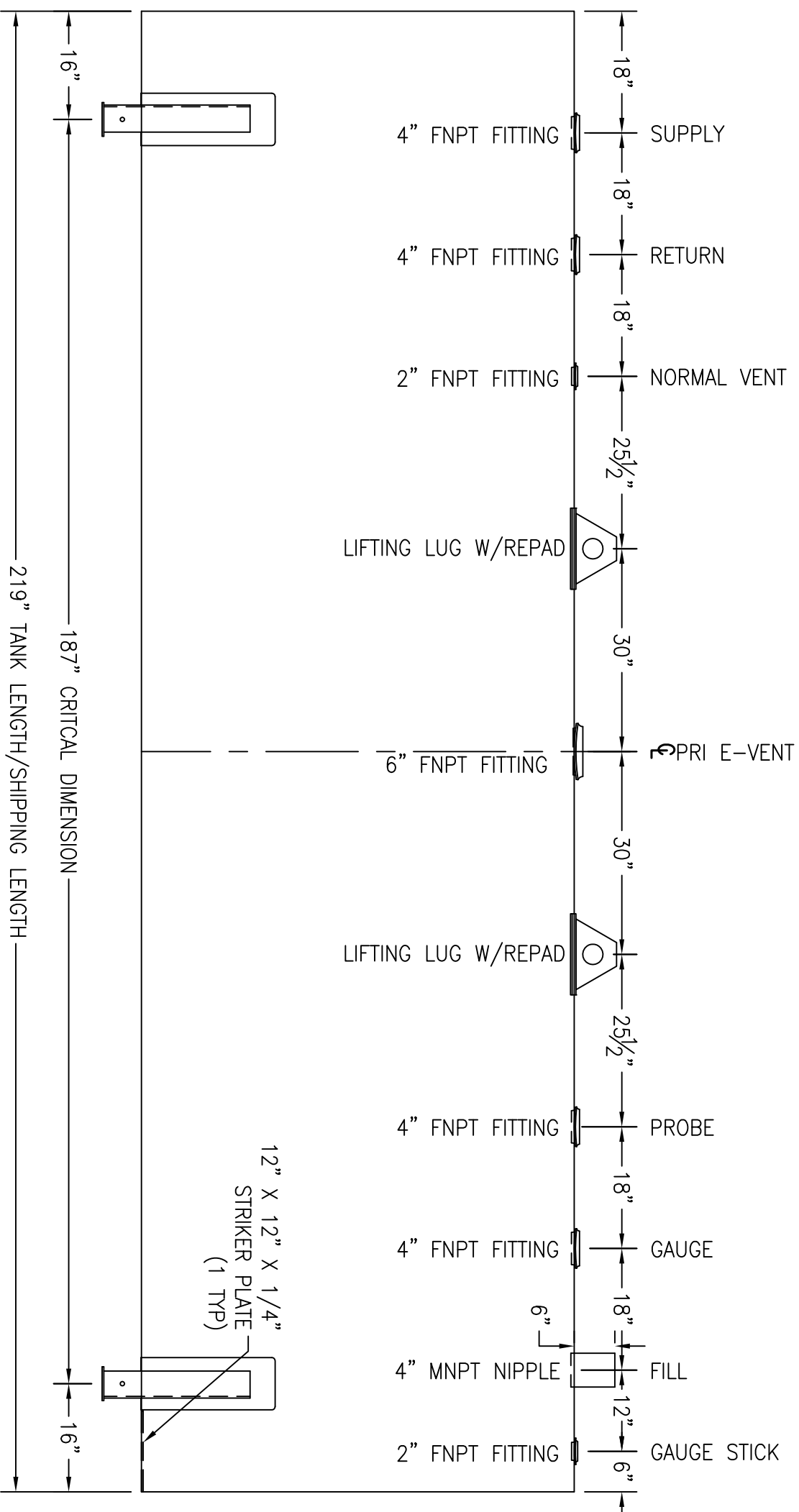

CUSTOMER APPROVAL SIGNATURE/DATE:

**3,000 GALLON HORIZONTAL S/W ABOVE GROUND TANK**

**SURFACE PREPARATION/COATING INFORMATION:**

INTERIOR SURFACES: SSPC-SP-3 POWER TOOL CLEAN WELDS ONLY  
 REMOVE ALL LOOSE DEBRIS  
 EXTERIOR SURFACES: SSPC-SP-6 COMMERCIAL BLAST  
 5-7 MILS ALIPHATIC URETHANE (WHITE)

**MATERIAL /CONSTRUCTION/ LABELING INFORMATION:**

MATERIAL: CARBON STEEL ASTM A 36 OR A 569  
 MATERIAL THICKNESS: PRIMARY TANK SHELL AND HEADS: 7 GA

LABELING/MARKING: UNDERWRITERS LABORATORIES UL-142

CUSTOMER:  
 PROJECT:  
 AGENT:



QUANTITY: ONE (1) REQUIRED  
 WEIGHT: 3,750 lbs ± 10%

P.O. BOX 1279 GOLDSBORO, NC 27533  
 PHONE: (919)751-1791 FAX: (919)751-8186  
 DRAWING NUMBER: GH03K64

REVISED 6/15