

*SADDLES ARE SEAL WELDED TO TANK

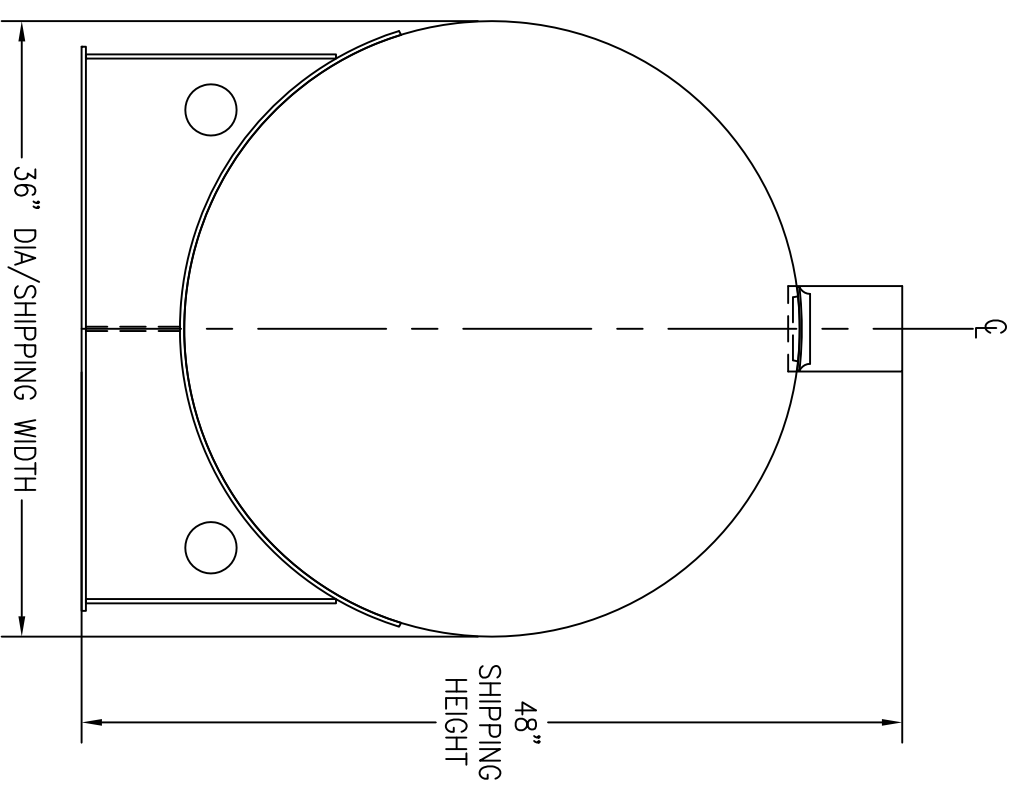
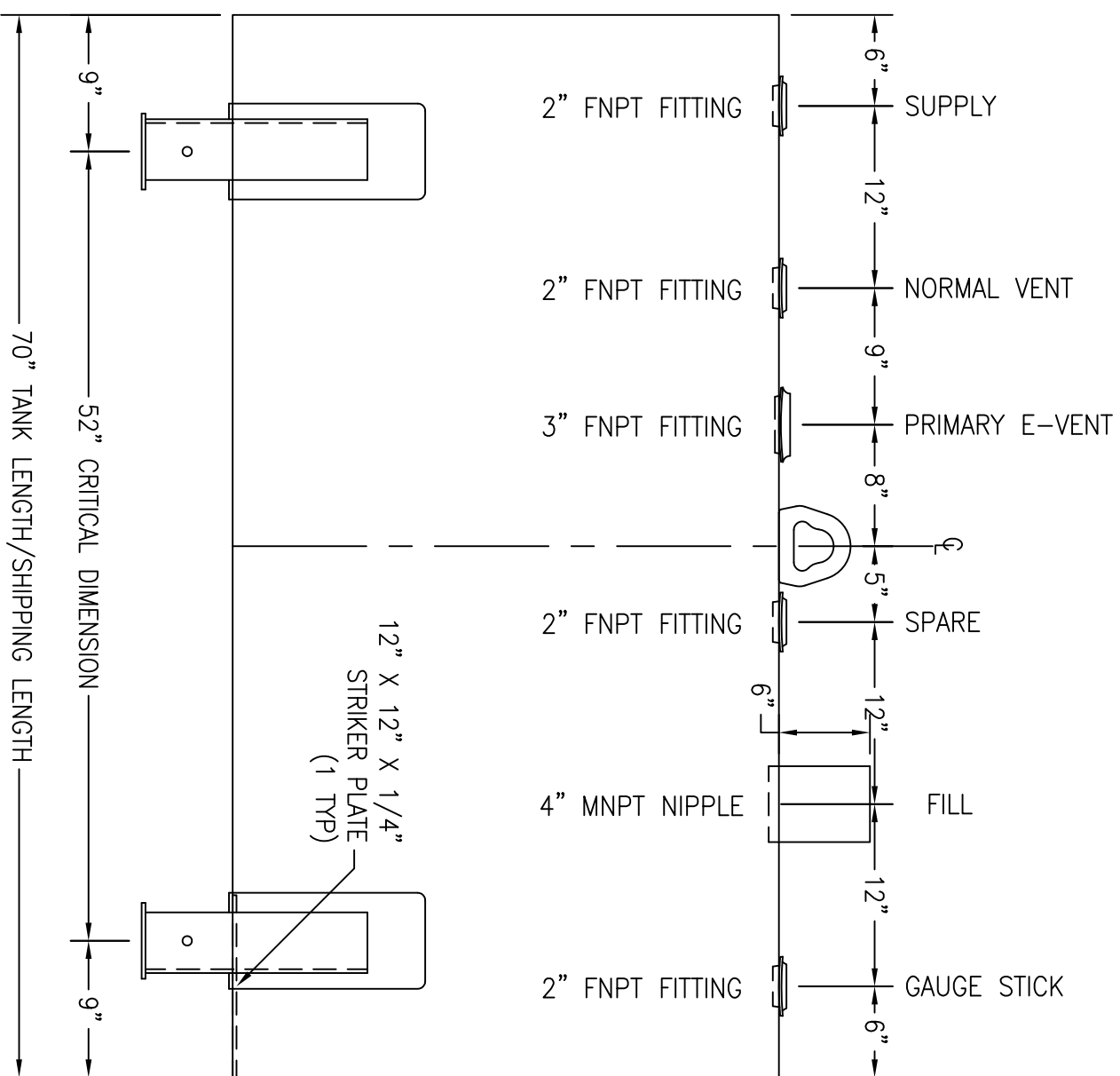

CUSTOMER APPROVAL SIGNATURE/DATE:

300 GALLON HORIZONTAL S/W ABOVE GROUND TANK

SURFACE PREPARATION/COATING INFORMATION:

INTERIOR SURFACES: SSPC-SP-3 POWER TOOL CLEAN WELDS ONLY
REMOVE ALL LOOSE DEBRIS

EXTERIOR SURFACES: SSPC-SP-6 COMMERCIAL BLAST
5-7 MILS ALIPHATIC URETHANE (WHITE)

MATERIAL /CONSTRUCTION/ LABELING INFORMATION:

MATERIAL: CARBON STEEL ASTM A 36 OR ASTM A 569
MATERIAL THICKNESS: PRIMARY TANK SHELL AND HEADS: 10 GA

LABELING/MARKING: UNDERWRITERS LABORATORIES UL-142

CUSTOMER:
PROJECT:
AGENT:



P.O. BOX 1279 GOLDSBORO, NC 27533
PHONE: (919)751-1791 FAX: (919)751-8186
DRAWING NUMBER: GIH30036

REVISED 6/15

QUANTITY: ONE (1) REQUIRED
WEIGHT: 1,250 lbs ± 10%

