

*SADDLES ARE SEAL WELDED TO TANK

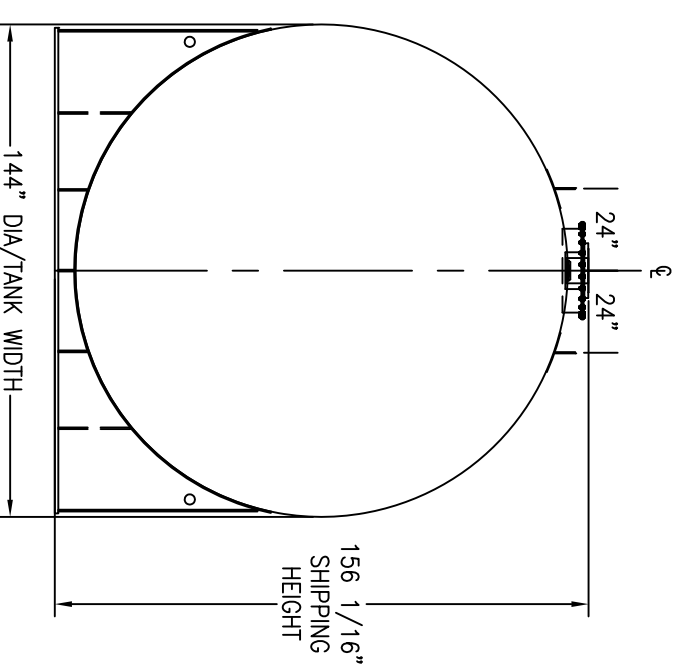
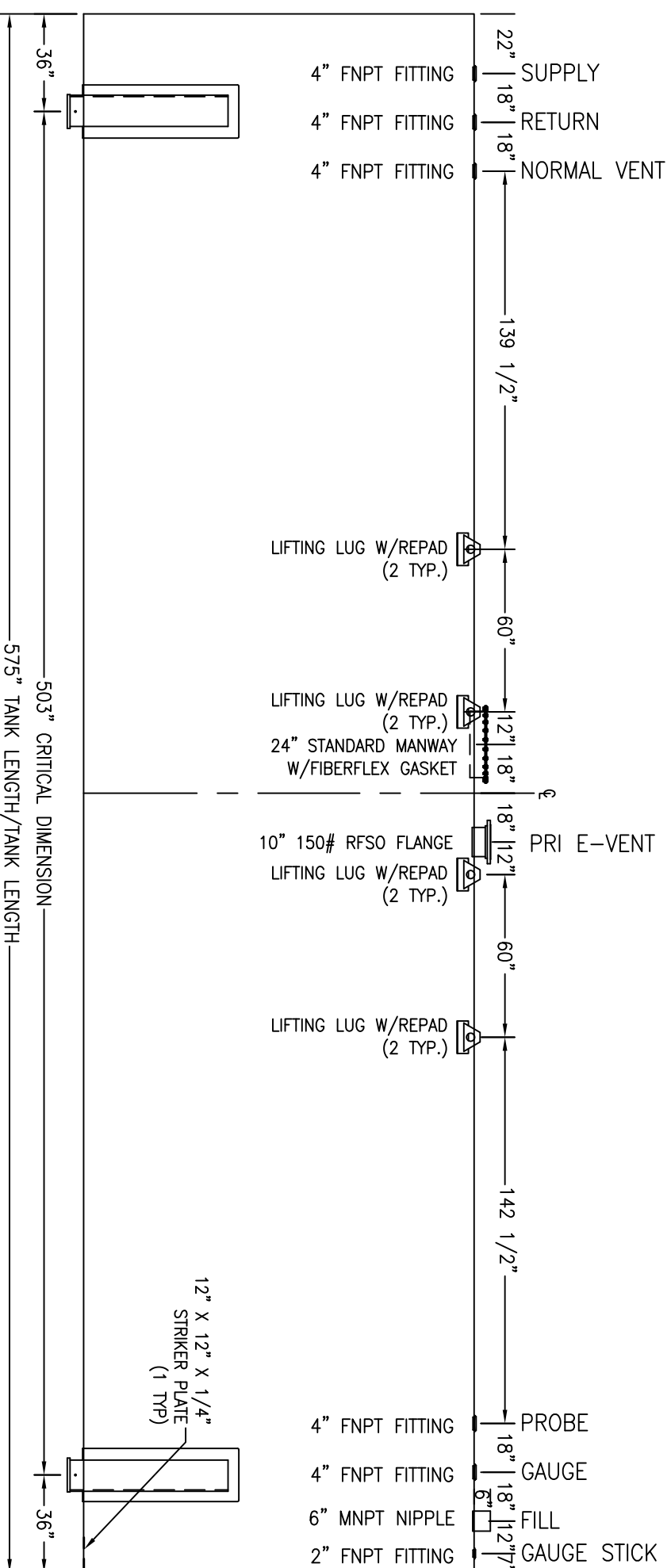

CUSTOMER APPROVAL SIGNATURE/DATE:

40,000 GALLON HORIZONTAL SW ABOVE GROUND TANK

SURFACE PREPARATION/COATING INFORMATION:

INTERIOR SURFACES: SSPC-SP-3 POWER TOOL CLEAN WELDS ONLY
 REMOVE ALL LOOSE DEBRIS
 EXTERIOR SURFACES: SSPC-SP-6 COMMERCIAL BLAST
 5-7 MILS ALIPHATIC URETHANE (WHITE)

MATERIAL /CONSTRUCTION/ LABELING INFORMATION:

MATERIAL: CARBON STEEL ASTM A 36 OR A 569
 MATERIAL THICKNESS: PRIMARY TANK SHELL: 3/8" PRIMARY HEADS: 5/16"

LABELING/MARKING: UNDERWRITERS LABORATORIES UL-142

CUSTOMER:
 PROJECT:
 AGENT:



QUANTITY: ONE (1) REQUIRED
 WEIGHT: 35,250 lbs ± 10%

P.O. BOX 1279 GOLDSBORO, NC 27533
 PHONE: (919)751-1791 FAX: (919)751-8186
 DRAWING NUMBER: GIH40K144 REVISED 6/15