

1/4" THICK STRIKER PLATES INSTALLED ON THE TANK INTERIOR BOTTOM UNDER EACH OPENING IN ACCORDANCE WITH STEEL TANK INSTITUTE
 24" x 24" x 1/4" ROTATOR ATTACHMENT PLATE WITH FIVE 3/4" x 3" LONG THREADED STUDS WELDED TO EACH HEAD, STUDS REMOVED PRIOR TO COMPLETION OF COATING OPERATION
 *** THIS TANK DESIGNED FOR MAXIMUM BURIAL DEPTH OF 5 FEET (GRADE TO TOP OF TANK) WITH APPROVED BACKFILL MATERIAL ***

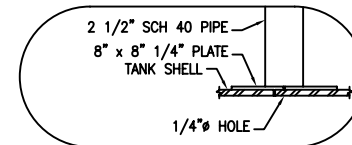

INTERSTITIAL MONITOR TUBE ASSEMBLY BOTTOM

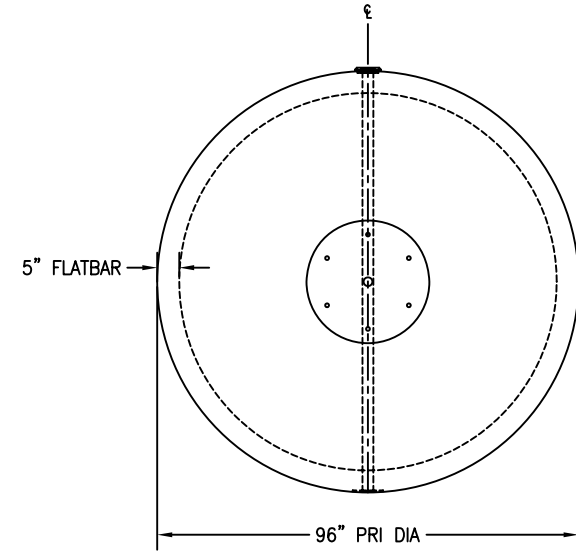
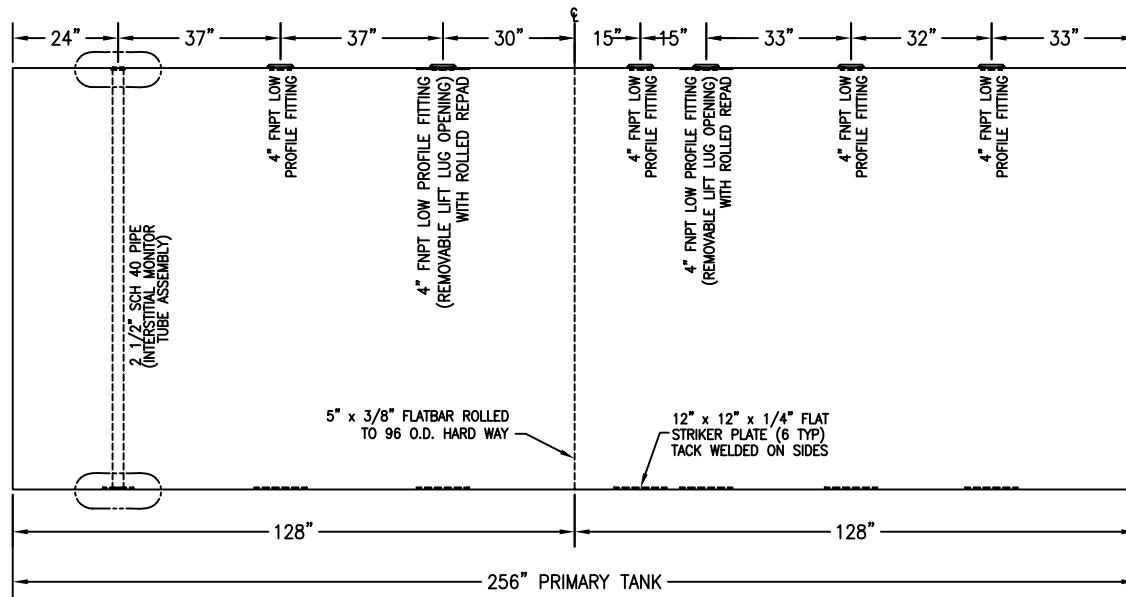
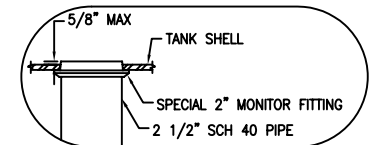

INTERSTITIAL MONITOR TUBE ASSEMBLY TOP

CUSTOMER APPROVAL SIGNATURE/DATE:

8000 GALLON D/W PERMATANK U/G STORAGE TANK

SURFACE PREPARATION/COATING INFORMATION:

INTERIOR SURFACES: N/A
 EXTERIOR SURFACES: SSPC-SP-6 COMMERCIAL BLAST CLEAN
 POLYPROPYLENE MESH STANDOFF/POLYESTER MYLAR FORMING INTERSTITIAL SPACE WITH 100 MILS MINIMUM STEEL TANK INSTITUTE APPROVED FIBERGLASS REINFORCED POLYESTER RESIN/CHEMICAL RESISTANT VEIL COATING (STEEL TANK ASSOCIATION POLYPROPYLENE STAND OFF MESH, 1 mil MINIMUM POLYESTER (MYLAR) FILM, REICHOLD CHEMICALS 33-402/33-404 POLYESTER RESIN, PPG HYBON 600 HTX FIBERGLASS ROVING, STEEL TANK ASSOCIATION 10 mil CHEMICAL RESISTANT SURFACING VEIL AND POST COAT WAX COATING)

MATERIAL /CONSTRUCTION/ LABELING INFORMATION:

MATERIAL: CARBON STEEL (ASTM A 36, ASTM A 635 OR ASTM A 569)
 MATERIAL THICKNESS: PRIMARY HEAD: 1/4" SHELL: 7 GA (ROARK .1594 w/ STIFFENER) SECONDARY TANK 100 mils FRP COATING
 CONSTRUCTION IN ACCORDANCE WITH UNDERWRITERS LABORATORIES UL-58 STANDARD FOR STEEL UNDERGROUND TANKS FOR FLAMMABLE AND COMBUSTIBLE LIQUIDS AND STEEL TANK INSTITUTE SPECIFICATION FOR PERMATANK
 LABELING/MARKING: UNDERWRITERS LABORATORIES UL-58 / STEEL TANK INSTITUTE PERMATANK / GENERAL INDUSTRIES NAMEPLATE

CUSTOMER:

PROJECT:

AGENT:



P.O. BOX 1279 GOLDSBORO, NC 27533
 PHONE: (919)751-1791 FAX: (919)751-8186

DRAWING NUMBER:

QUANTITY: ONE (1) REQUIRED
 WEIGHT: 7,750 lb ± 5%