

NOTES:

- 1) ALL OPENINGS INSTALLED WITH DI-ELECTRIC BUSHINGS OR SPOOL FLANGES AND FLANGE ISOLATION KITS IN ACCORDANCE WITH STEEL TANK INSTITUTE
- 2) THIS TANK DESIGNED FOR A BURIAL DEPTH OF 5 FEET (GRADE TO TOP OF TANK) WITH APPROVED BACKFILL MATERIAL *****

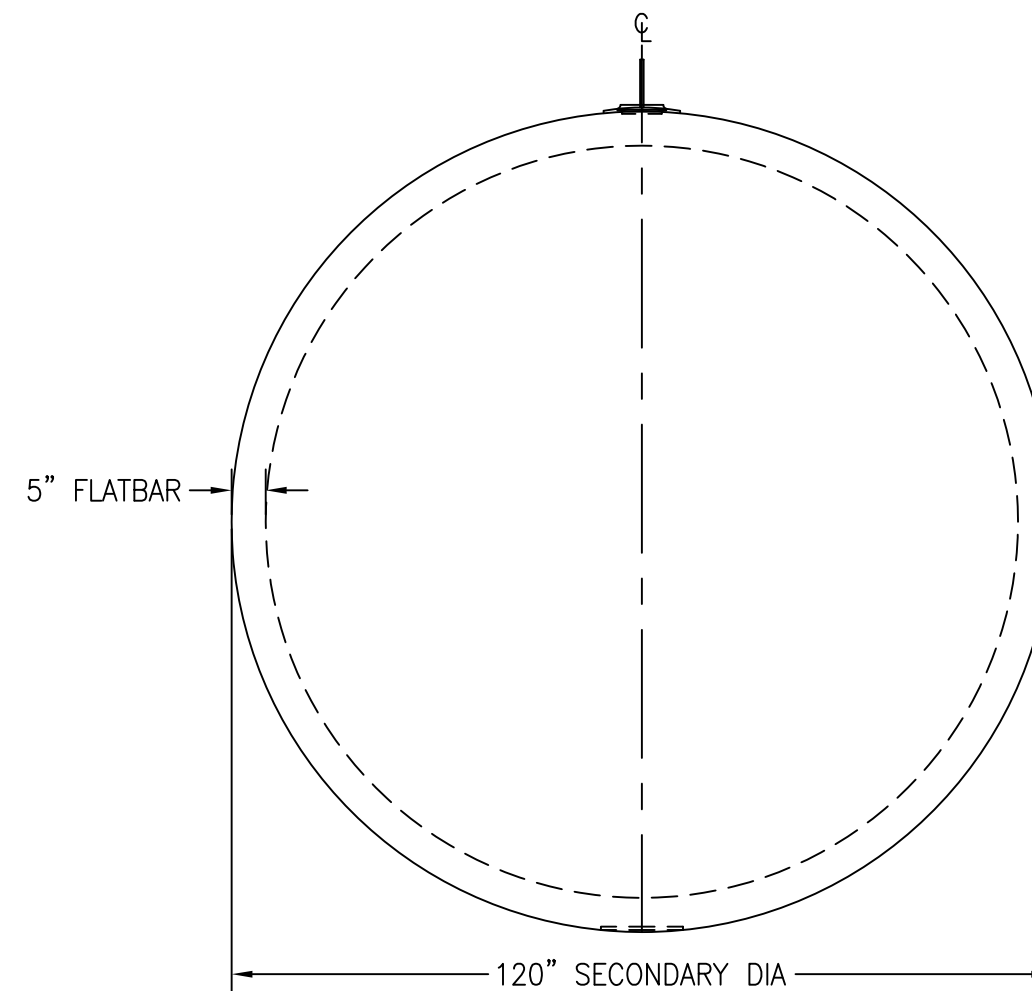
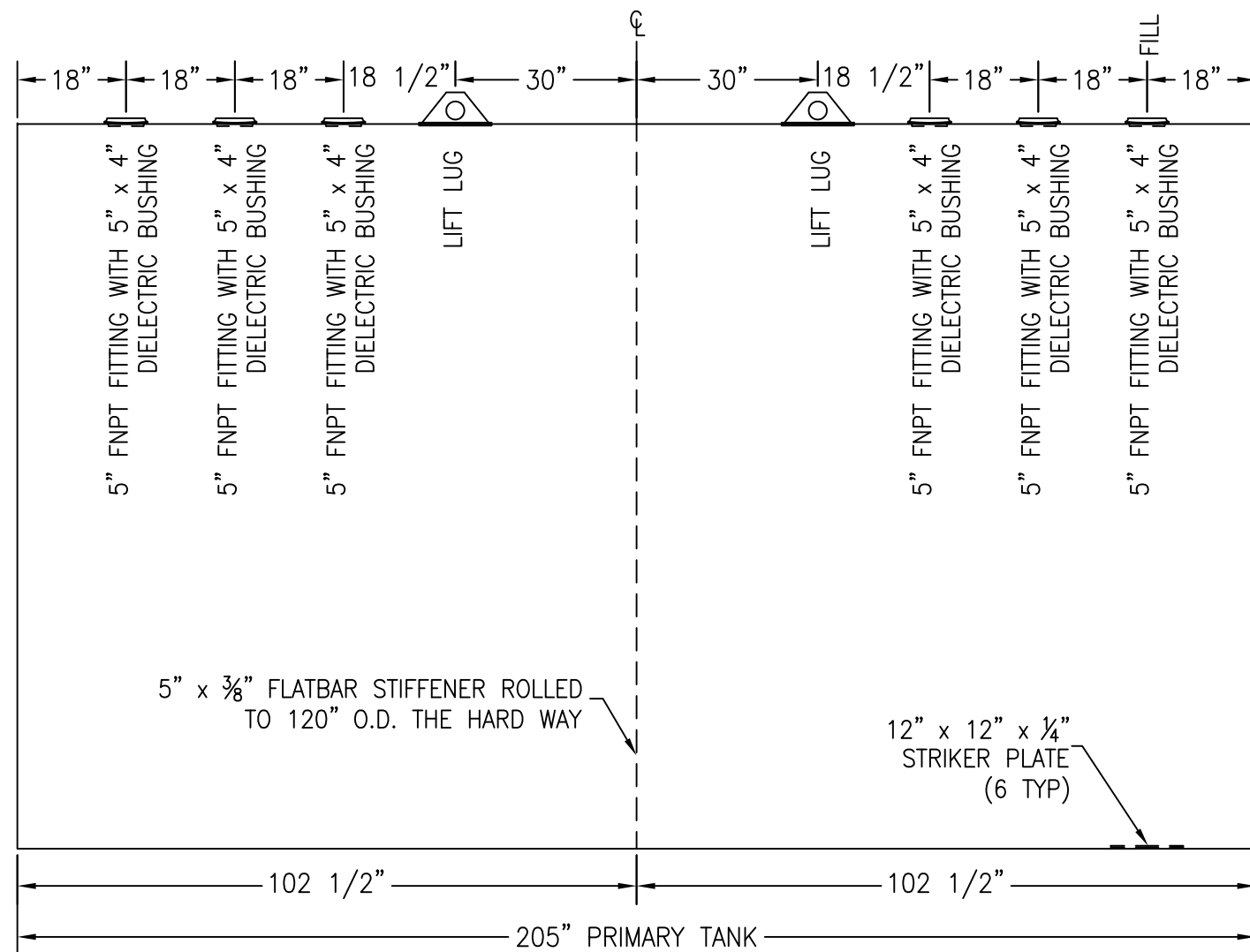

CUSTOMER APPROVAL SIGNATURE/DATE:

10,000 GALLON S/W UNDER LECHATE GROUND TANK

SURFACE PREPARATION/COATING INFORMATION:
 INTERIOR SURFACES: SSPC-SP-3 POWER TOOL CLEAN WELDS ONLY REMOVE ALL LOOSE DEBRIS

 EXTERIOR SURFACES: SSPC-SP-6 COMMERCIAL BLAST CLEAN 75 mils UL-1746 APPROVED POLYURETHANE COATING

MATERIAL /CONSTRUCTION/ LABELING INFORMATION:
 MATERIAL: CARBON STEEL ASTM A 36 OR A 569
 MATERIAL THICKNESS: PRIMARY HEADS: 1/4" PRIMARY TANK: ROARK MIN. 0.1716 w/STIFFENER

 LABELING/MARKING: UNDERWRITERS LABORATORIES UL-58

CUSTOMER:
 PROJECT:
 AGENT:

GENERAL INDUSTRIES

P.O. BOX 1279 GOLDSBORO, NC 27533
 PHONE: (919)751-1791 FAX: (919)751-8186

DRAWING NUMBER:
GIWUG-L-10120 11/2014

QUANTITY: ONE (1) REQUIRED
 WEIGHT: 7,000 lbs ± 10%