

Parts List

ITEM	QTY	SIZE	RATING	TYPE	MATERIAL	PROJ. OUT	FUNCTION	ITEM	QTY	SIZE	RATING	TYPE	MATERIAL	PROJ. OUT	FUNCTION
A	1	2"	FNPT	COUPLING	C.S		INTERSTITIAL MONITOR PIPE	H	1	10"	150#	RFSD	C.S	5 11/16"	PRIMARY E-VENT
B	1	4"	FNPT	COUPLING	C.S	2 1/2"	SUPPLY	I	1	4"	FNPT	COUPLING	C.S	2 1/2"	PROBE
C	1	4"	FNPT	COUPLING	C.S	2 1/2"	RETURN	J	1	4"	FNPT	COUPLING	C.S	2 1/2"	GAUGE
D	1	4"	FNPT	COUPLING	C.S	2 1/2"	NORMAL VENT	K	1	6"	MNPT	NIPPLE	C.S	6"	FILL
E	1	24"			C.S	7"	24" STANDARD MANWAY	L	1	2"	FNPT	COUPLING	C.S	1 1/8"	GAUGE STICK
F	8	-	-	-	C.S	-	LIFT LUG								
G	1	10"	150#	RFSD	C.S	5 11/16"	SECONDARY E-VENT								

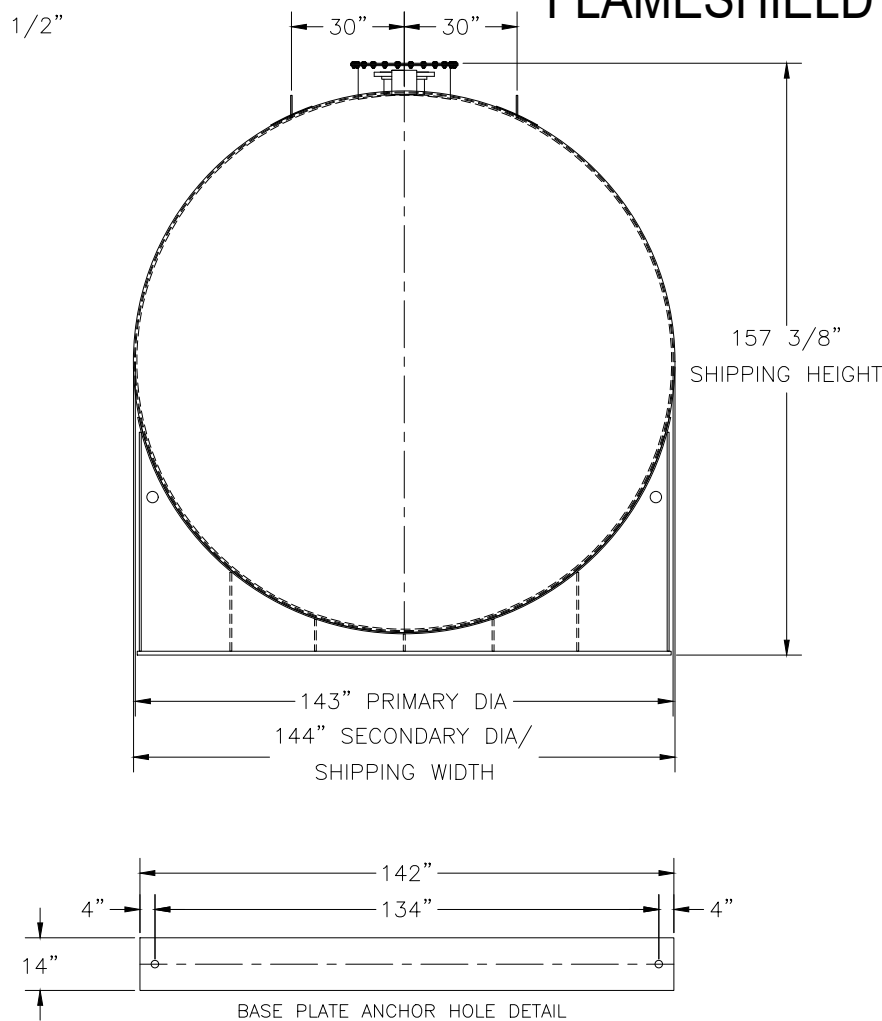
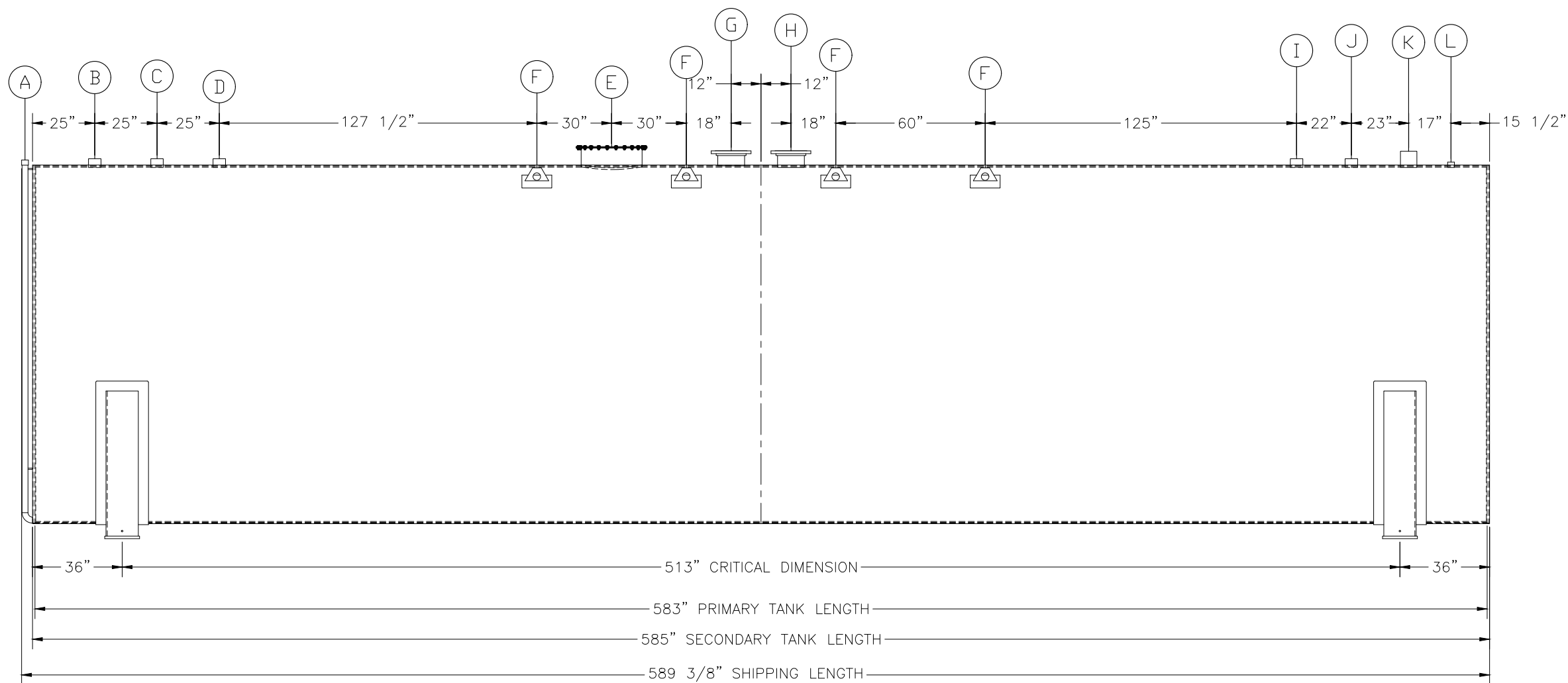

CUSTOMER APPROVAL SIGNATURE/DATE:

40,000 GALLON HORIZONTAL FLAMESHIELD D/W ABOVE GROUND TANK

DESIGN DATA

OPERATING PRESSURE: ATMOSPHERIC	JOINT DESIGN: LAP WELD
SPECIFIC GRAVITY: 1.0	ALL LINEAR DIMENSIONS SHALL BE ±1/4" AND ANGULAR DIMENSIONS WITHIN ±1°
TANK MATERIAL: ASTM A36 CARBON STEEL	INTERIOR SURFACES: SSPC-SP-3 (POWER TOOL CLEAN)
PRIMARY SHELL: 3/8" PRIMARY HEADS: 5/16"	EXTERIOR SURFACES: SSPC-SP-6 BLAST & 5-7 MILS WHITE URETHANE
SECONDARY SHELL: 7GA SECONDARY HEADS: 1/4"	
	LABEL/MARKING: UNDERWRITERS LABORATORIES UL-142, FLAMESHIELD

CUSTOMER:
PROJECT:
AGENT:



P.O. BOX 1279 GOLDSBORO, NC 27533
PHONE: (919)751-1791 FAX: (919)751-8186

DRAWING NUMBER:
GIFS40K144SAD

1.11.2022

QUANTITY: ONE (1) REQUIRED
WEIGHT: 57,000 lbs ± 10%

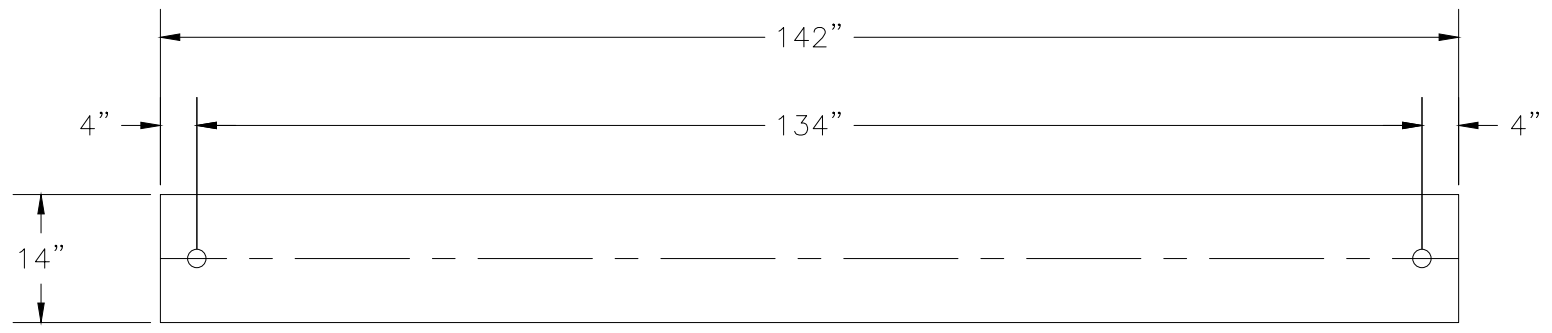

BASE PLATE ANCHOR HOLE DETAIL

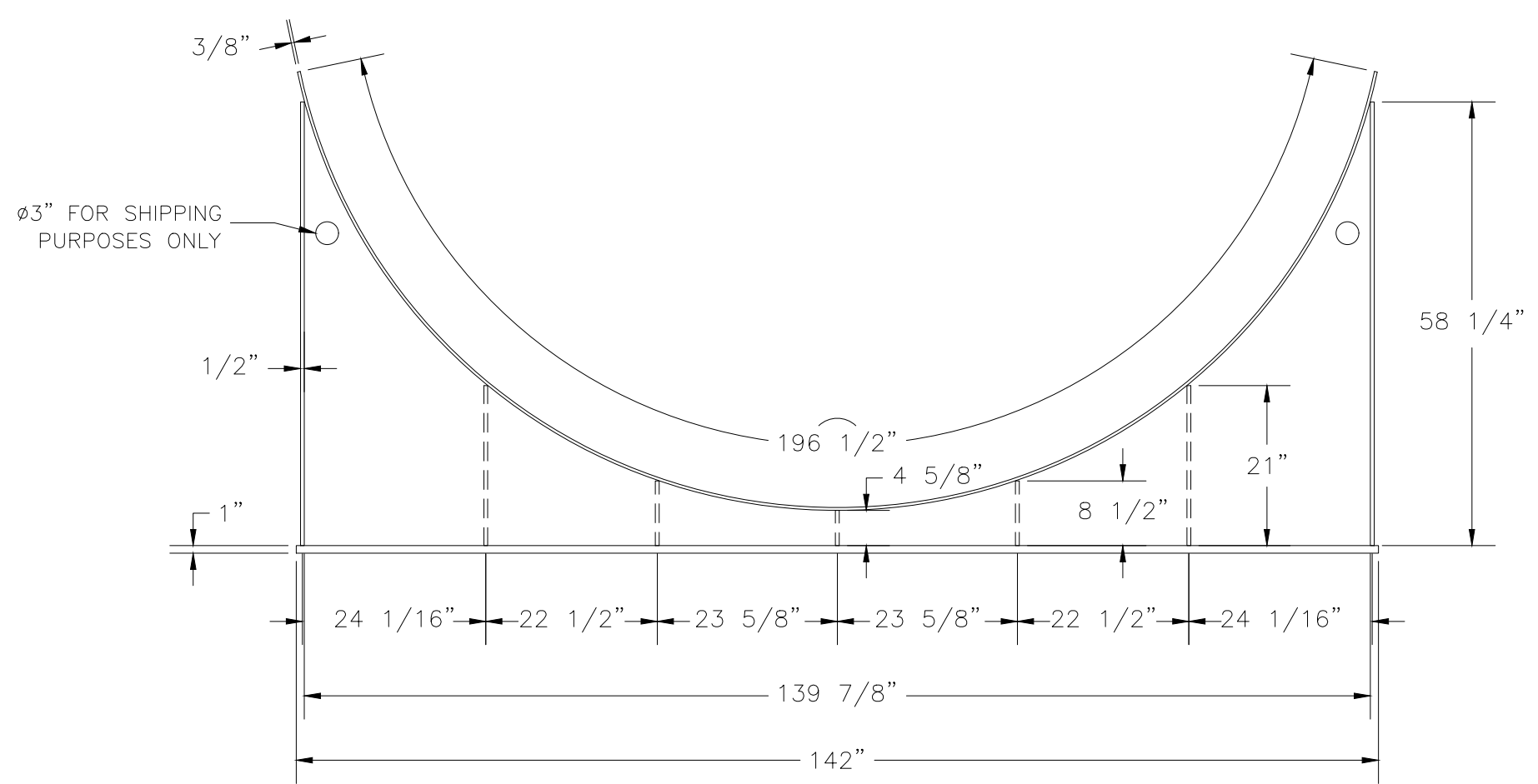
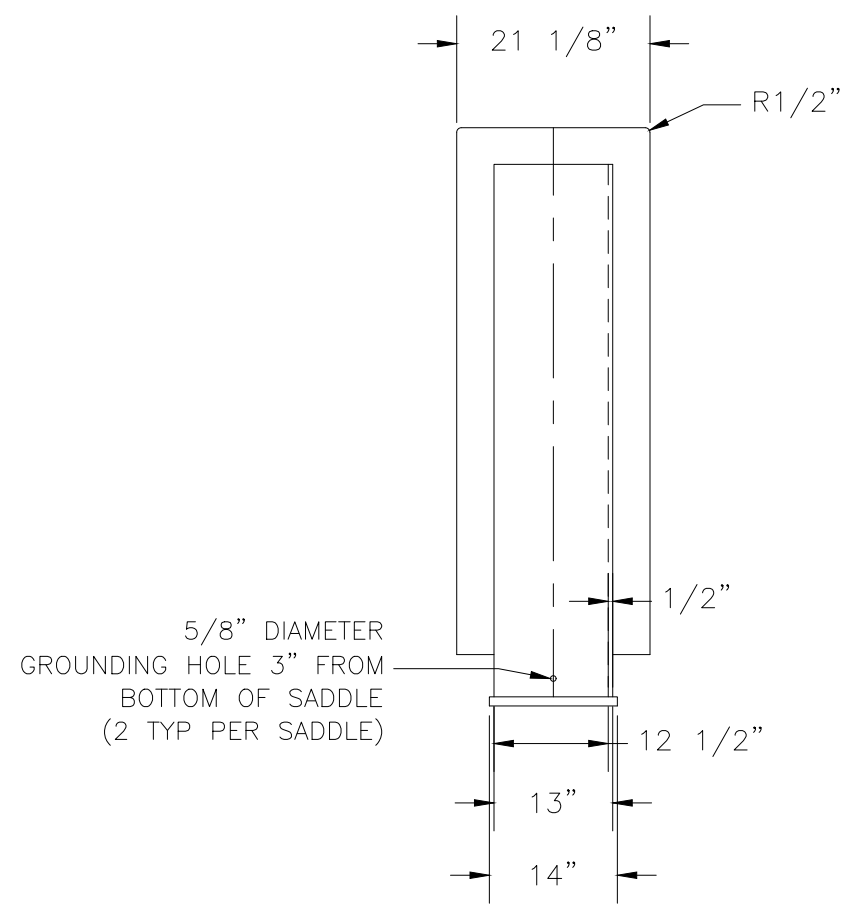

CUSTOMER APPROVAL SIGNATURE/DATE:

40,000 GAL 6" TALL SADDLE FOR 144" DIAMETER TANK

DESIGN DATA
MATERIAL - ASTM A 36 CARBON STEEL
EXTERIOR SURFACES: SSPC-SP-6 ONE COAT ZINC EPOXY PRIMER & 5-7MILS WHITE URETHANE

CUSTOMER:
PROJECT:
AGENT:



P.O. BOX 1279 GOLDSBORO, NC 27533
PHONE: (919)751-1791 FAX: (919)751-8186
DRAWING NUMBER:
GIFS40K144SAD/1 1.11.2022

QUANTITY: TWO (2) REQUIRED
WEIGHT: 1,956 lbs ± 10%